

THE NETHERLANDS
(N E D E R L A N D)

COMMUNICATION

Concerning ⁽¹⁾:

- approval granted
- ~~approval extended~~
- ~~approval refused~~
- ~~approval withdrawn~~
- ~~production definitively discontinued~~

of a type of front position lamps, rear position lamps, stop lamps, direction indicators and rear-registration-plate illuminating devices for mopeds, motor cycles and vehicles treated as such pursuant to Regulation number 50.

Approval number: E4*50R00/20*3089*00

1. Trade name or mark of the device : K-LITE
2. Manufacturer's name for the type of device : M310
3. Manufacturer's name and address : K-Lite (Yuyao) Plastics Co., Ltd.
No.5 Workshop, No.20 Xingye Road,
Yangming Industrial Zone, Yuyao City,
Zhejiang Province, 315400 China (PRC)
4. If applicable, name and address of the manufacturer's representative : Not applicable
5. Submitted for approval on : 27/03/2020
6. Technical service responsible for conducting approval tests : IDIADA
L'Albornar- PO Box 20
E-43710 Santa Oliva (Tarragona)
SPAIN
7. Date of report issued by that service : 01/04/2020
8. Number of report issued by that service : CN20030833



9. Concise description ⁽²⁾ :
- By category of lamp : 11 and 12
- Colour of light emitted : ~~red/white~~/amber ⁽¹⁾
- Number and category(ies) of light source(s) : 3 x LEDs
- Light source module : ~~yes~~/no ⁽¹⁾
- Light source module specific identification code : ---
- Geometrical conditions of installation and relating variations, if any : ---
- Application of an electronic light source control gear/variable intensity control:
- (a) Being part of the lamp : ~~yes/no~~/not applicable ⁽¹⁾
- (b) Being not part of the lamp : ~~yes/no~~/not applicable ⁽¹⁾
- Input voltage(s) supplied by an electronic light source control gear/variable intensity control : ---
- Electronic light source control gear/variable intensity control manufacturer and identification number (when the light source control gear is part of the lamp but is not included into the lamp body) : ---
- Only for limited mounting height of equal to or less than 750 mm above the ground : ~~yes~~/no ⁽¹⁾
- Function(s) produced by an interdependent lamp forming part of an interdependent lamp system:
- Front position lamp : ~~yes~~/no ⁽¹⁾
- Rear position lamp : ~~yes~~/no ⁽¹⁾
- Stop lamp : ~~yes~~/no ⁽¹⁾
- Sequential activation of light sources (see paragraph 6.8. of this Regulation) : ~~yes~~/no ⁽¹⁾
10. Position of the approval mark : Marked on Lens
11. Reason(s) for extension (if applicable) : ---



12. Approval : granted/~~extended/refused/withdrawn~~⁽¹⁾
13. Place : Zoetermeer
14. Date : 16 April 2020
15. Signature :

Uwe Löbig



16. The list of documents deposited with the Administrative Service which has granted approval is annexed to this communication and may be obtained upon request.

⁽¹⁾ Strike out what does not apply.

⁽²⁾ With regard to lighting and light-signalling lamps, when an assembly comprising several lamps designated by a single number has been approved, a single form may be prepared. It is sufficient to indicate:

- In the heading, the names of the lamps in question;
- The number of the various relevant regulations.

In this case, the item "Concise description" is to be prepared as an annex containing the following information for each lamp, where applicable:

- (a) Number and category of light source(s);
- (b) Rated voltage;
- (c) Category of the device;
- (d) Colour of light emitted.

IDIADA

TECHNICAL DOCUMENTATION



IDIADA CN20030833

Application date : March 27, 2020

1. Specification data

Type		M310	
Function		Direction indicator	
Emitted color		Amber	
Rated	Voltage	12V	
	Wattage	1W	
Applicable Regulation (UN)		R50.00 Category 11 and 12	
Number and category of light source		3xLEDs, Non-replaceable light source	
Location of marking	Rated V and W	Marked on Lens	
	Trade mark	K-LITE	Marked on Lens
	Approval mark	Marked on Lens	

2. Construction and material

Construction	Material	Remarks
Outer Lens	PMMA	Clear
Housing	Zinc Alloy	Black
Electrical wiring	-	---

3. Name and address of manufacturer : K-Lite (Yuyao) Plastics Co., Ltd.
No.5 Workshop, No.20 Xingye Road,
Yangming Industrial Zone, Yuyao City,
Zhejiang Province, 315400 China (PRC)

4. Name and address of representative of manufacturer : Not applicable

This information document consists of 3 pages.



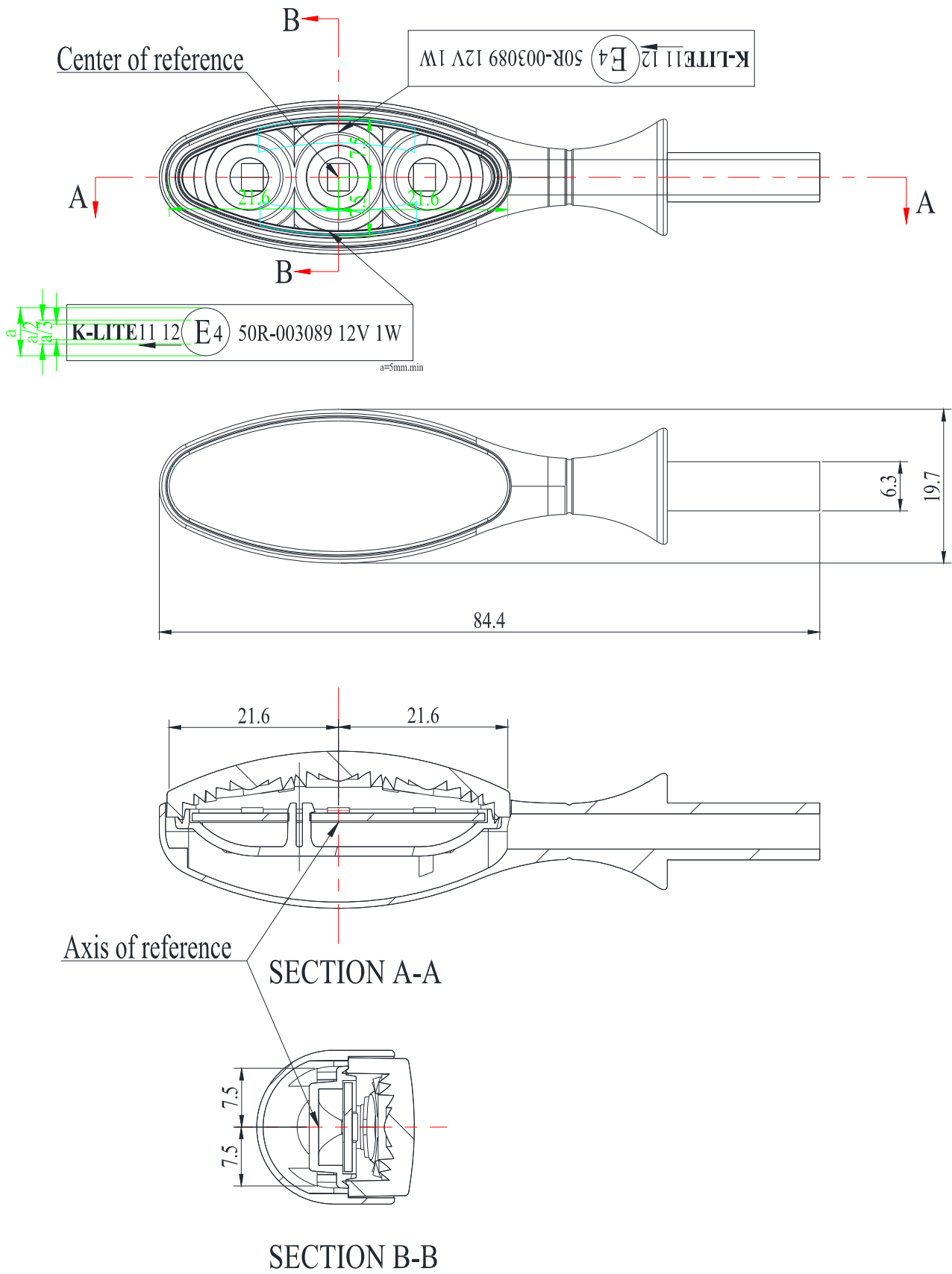

CIRCUIT DIAGRAM

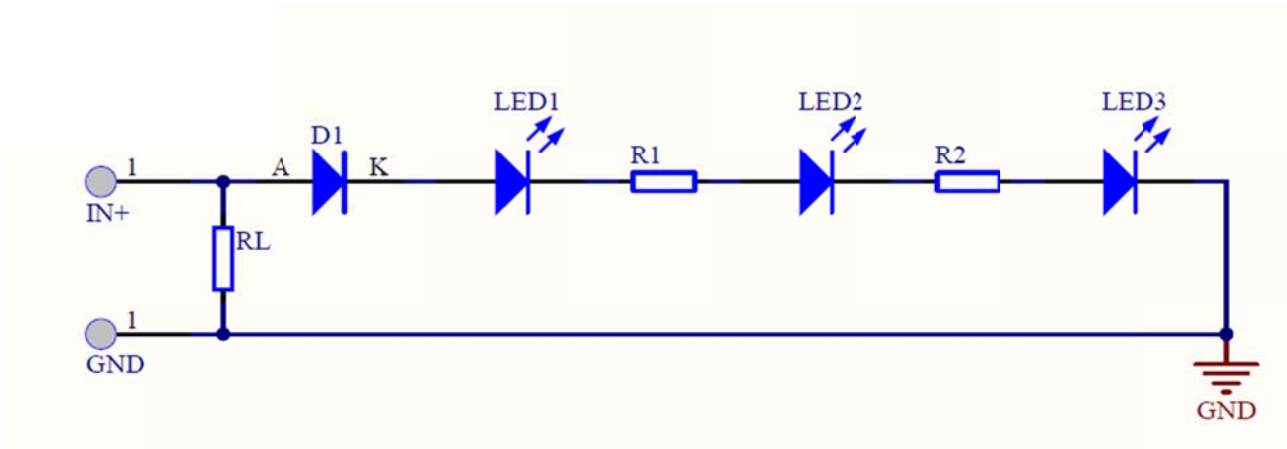

Direction indicator: 3xLEDs, 12V 1W, Non-replaceable light source

REPORT No. CN20030833

CONCERNING THE APPROVAL OF FRONT POSITION LAMPS, REAR POSITION LAMPS, STOP LAMPS, DIRECTION INDICATORS AND REAR-REGISTRATION-PLATE ILLUMINATING DEVICES FOR VEHICLES OF CATEGORY L ACCORDING TO REGULATION 50.00 UN

Manufacturer's name and address : K-Lite (Yuyao) Plastics Co., Ltd.
No.5 Workshop, No.20 Xingye Road,
Yangming Industrial Zone, Yuyao City,
Zhejiang Province, 315400 China (PRC)

Trade mark : K-LITE

Type : M310

Place and date of test report issue : L'Albornar, Santa Oliva (Tarragona)
01/04/2020

CONCLUSIONS: This device **FULFILLS** with the prescriptions with regard to the approval of direction indicators of category 11 in application to Regulation No. 50.00 UN, as detailed in the annex to this report.

Performed by:



Joan Fonts Sala
TEST ENGINEER

Revised by:



Lluís Sans Gomis
DEPARTMENT MANAGER

ANNEX TO THE REPORT**CONCERNING THE APPROVAL OF FRONT POSITION LAMPS, REAR POSITION LAMPS, STOP LAMPS, DIRECTION INDICATORS AND REAR-REGISTRATION-PLATE ILLUMINATING DEVICES FOR VEHICLES OF CATEGORY L ACCORDING TO REGULATION 50.00 UN**

Manufacturer's name and address : K-Lite (Yuyao) Plastics Co., Ltd.
No.5 Workshop, No.20 Xingye Road,
Yangming Industrial Zone, Yuyao City,
Zhejiang Province, 315400 China (PRC)

Trade mark : K-LITE

Type : M310

Variants : ---

Sample identification : CN20030833

Lamp : - Single (2.14 (a) R.53)

Light source(s) number and category(ies) : 3 x LEDs

Light source module * : ~~Yes~~ -No

Light source module specific identification code: ----

* Strike out what does not apply

MARKING

Marking	CORRECT
---------	----------------

GENERAL SPECIFICATIONS

The requirements contained in sections 5. "General specifications" and 6. "Individual specifications" and in the Annexes referenced in the said sections of Regulations Nos. 53 or 74, and their series of amendments in force at the time of application for the lamp type approval shall apply to this Regulation. The requirements pertinent to each lamp and to the category/ies of vehicle on which the lamp is intended to be installed shall be applied, where its verification at the moment of lamp type approval is feasible.	CORRECT
Vibration endurance	CORRECT

LIGHT SOURCE MODULES

The design of the light source module(s) shall be such as: a) That each light source module can only be fitted in no other position than the designated and correct one and can only be removed with the use of tool(s); b) If there are more than one light source module used in the housing for a device, light source modules having different characteristics cannot be interchanged within the same lamp housing.	NOT APPLICABLE
The light source module(s) shall be tamperproof.	NOT APPLICABLE
A light source module shall be so designed that regardless of the use of tool(s), it shall not be mechanically interchangeable with any replaceable approved light source.	NOT APPLICABLE

* THE PRESENTED RESULTS REFER ONLY TO THE TESTED SAMPLE.
* THE PARTIAL REPRODUCTION OF THIS REPORT WITHOUT THE PERMISSION OF IDIADA IS COMPLETELY FORBIDDEN.
* MEASUREMENT UNCERTAINTY OF THE RESULTS HAS BEEN CALCULATED BY THE LABORATORY.

REPLACEABLE LIGHT SOURCE(S)

Light source approved according to Regulation UN No. 37 and/or Regulation UN No. 128.	NOT APPLICABLE
The design of the device shall be such that the light source cannot be fixed in any other position but the correct one.	NOT APPLICABLE
The light source holder shall conform to the characteristics given in IEC Publication 60061.	NOT APPLICABLE

NON-REPLACEABLE FILAMENT LAMP OR LIGHT SOURCE MODULE EQUIPPED WITH NON-REPLACEABLE FILAMENT LAMP(S)

In the case of non-replaceable filament lamp(s) or light source module(s) equipped with non-replaceable filament lamp(s), the applicant shall annex to the type approval documentation a report (by the light source manufacturer indicated in the type approval documentation), acceptable to the Authority responsible for type approval, that demonstrates compliance of these non-replaceable filament lamp(s) with the requirements as specified in paragraph 4.11. of IEC 60809, Edition 3.	NOT APPLICABLE
---	-----------------------

CN20030833

IDIADA



* THE PRESENTED RESULTS REFER ONLY TO THE TESTED SAMPLE.
 * THE PARTIAL REPRODUCTION OF THIS REPORT WITHOUT THE PERMISSION OF IDIADA IS COMPLETELY FORBIDDEN.
 * MEASUREMENT UNCERTAINTY OF THE RESULTS HAS BEEN CALCULATED BY THE LABORATORY.

SEQUENTIAL ACTIVATION OF LIGHT SOURCE(S)

Each light source, after its activation, shall remain lit until the end of the ON cycle.	NOT APPLICABLE
The sequence of activation of the light sources shall produce a signal which proceeds in a uniform progressive manner from inboard towards the outboard edge of the light emitting surface.	NOT APPLICABLE
It shall be one signal with no interruption and no vertical oscillations (e.g. not more than one change of direction along the vertical axis). The distance between two adjacent/tangential distinct parts of the light emitting surface of the sequential direction indicator shall not exceed 50mm, when measured perpendicularly to the reference axis, instead of the values defined in paragraph 5.7.2. of Regulation 48. These interruptions of the signal shall not create any overlap in the vertical axis between the different parts, from inboard towards the outboard of the vehicle, and shall not be used for any other lighting or light signalling functions.	NOT APPLICABLE
The variation shall finish no more than 200 ms after the beginning of the ON cycle. $T_{ON} = \text{--- ms}$	NOT APPLICABLE
The orthogonal projection of the light emitting surfaces of the direction indicator in the direction of the axis of reference shall be circumscribed by a rectangle on a plane normal to the axis of reference and having its longer sides parallel to the H-plane. The ratio of the horizontal to the vertical sides shall not be less than 1.7.	NOT APPLICABLE

CN20030833

IDIADA



* THE PRESENTED RESULTS REFER ONLY TO THE TESTED SAMPLE.
 * THE PARTIAL REPRODUCTION OF THIS REPORT WITHOUT THE PERMISSION OF IDIADA IS COMPLETELY FORBIDDEN.
 * MEASUREMENT UNCERTAINTY OF THE RESULTS HAS BEEN CALCULATED BY THE LABORATORY.

COLORIMETRIC SPECIFICATIONS

AMBER ZONE:

- Limit towards the green: $y \leq x - 0.120$
- Limit towards the red: $y \geq 0.390$
- Limit towards the white: $y \geq 0.790 - 0.670x$

Chromatic co-ordinates (reference axis)	SAMPLE A	SAMPLE B
x	0.5621	0.5637
y	0.4258	0.4256
z	0.0121	0.0107

Test result: The samples tested fulfil with the colorimetric specifications within the field of the light distribution grid defined in the present Regulation. Outside this field no sharp variation of colour is observed.

PHOTOMETRIC SPECIFICATIONS

1. Luminous intensities measured after one minute of operation.

	SAMPLE A	SAMPLE B
Luminous intensity in the angular field specified: $1000 \geq I(\text{cd}) \geq 0.3$ H = 80° outboard / 20° inboard; V = 15° upwards / 15° downwards H = 80° outboard / 20° inboard; V = 15° upwards / 5° downwards: device installed with the H plane of the lamp with mounting height < 750 mm above the ground	$I_{\text{max}} (\text{cd}) = 116.8$ $I_{\text{min}} (\text{cd}) = 2.557$ CORRECT	$I_{\text{max}} (\text{cd}) = 121.0$ $I_{\text{min}} (\text{cd}) = 2.554$ CORRECT

* THE PRESENTED RESULTS REFER ONLY TO THE TESTED SAMPLE.
 * THE PARTIAL REPRODUCTION OF THIS REPORT WITHOUT THE PERMISSION OF IDIADA IS COMPLETELY FORBIDDEN.
 * MEASUREMENT UNCERTAINTY OF THE RESULTS HAS BEEN CALCULATED BY THE LABORATORY.

SPATIAL LUMINOUS DISTRIBUTION TABLE

SAMPLE A

H→ V↓	20°	10°	5°	0°	5°	10°	20°
max 10° min			1000 68.37Cd 18.0		1000 58.34Cd 18.0		
max 5° min	1000 14.12Cd 9.0	1000 61.02Cd 18.0		1000 115.6Cd 63.0		1000 45.84Cd 18.0	1000 12.80Cd 9.0
max 0° min		1000 54.10Cd 31.5	1000 98.02Cd 81.0	1000 104.9Cd 90.0	1000 88.16Cd 81.0	1000 44.41Cd 31.5	
max 5° min	1000 11.78Cd 9.0	1000 32.60Cd 18.0		1000 70.68Cd 63.0		1000 35.49Cd 18.0	1000 12.49Cd 9.0
max 10° min			1000 28.67Cd* 18.0		1000 34.78Cd* 18.0		

SAMPLE B

H→ V↓	20°	10°	5°	0°	5°	10°	20°
max 10° min			1000 50.91Cd 18.0		1000 36.32Cd 18.0		
max 5° min	1000 20.86Cd 9.0	1000 78.32Cd 18.0		1000 80.75Cd 63.0		1000 31.28Cd 18.0	1000 13.42Cd 9.0
max 0° min		1000 99.76Cd 31.5	1000 120.8Cd 81.0	1000 103.5Cd 90.0	1000 93.76Cd 81.0	1000 35.55Cd 31.5	
max 5° min	1000 15.97Cd 9.0	1000 85.08Cd 18.0		1000 78.67Cd 63.0		1000 33.26Cd 18.0	1000 17.00Cd 9.0
max 10° min			1000 55.60Cd* 18.0		1000 40.90Cd* 18.0		

* In the case where the lamp is intended to be installed at a mounting height of equal to or less than 750 mm above the ground, the photometric intensity is verified only up to an angle of 5° downwards (2.1.3 Annex 4)

* THE PRESENTED RESULTS REFER ONLY TO THE TESTED SAMPLE.
 * THE PARTIAL REPRODUCTION OF THIS REPORT WITHOUT THE PERMISSION OF IDIADA IS COMPLETELY FORBIDDEN.
 * MEASUREMENT UNCERTAINTY OF THE RESULTS HAS BEEN CALCULATED BY THE LABORATORY.



2. Luminous intensities measured after 30 minutes of operation.

	SAMPLE A	SAMPLE B
Luminous intensity in the angular field specified: $1000 \geq I(\text{cd}) \geq 0.3$ H = 80° outboard / 20° inboard; V = 15° upwards / 15° downwards H = 80° outboard / 20° inboard; V = 15° upwards / 5° downwards: device installed with the H plane of the lamp with mounting height < 750 mm above the ground	$I_{\text{max}} (\text{cd}) = 116.1$ $I_{\text{min}} (\text{cd}) = 2.543$ CORRECT	$I_{\text{max}} (\text{cd}) = 120.3$ $I_{\text{min}} (\text{cd}) = 2.539$ CORRECT

SPATIAL LUMINOUS DISTRIBUTION TABLE

SAMPLE A

H→ V↓	20°	10°	5°	0°	5°	10°	20°
max 10° min			1000 67.99Cd 18.0		1000 58.02Cd 18.0		
max 5° min	1000 14.04Cd 9.0	1000 60.67Cd 18.0		1000 115.0Cd 63.0		1000 45.58Cd 18.0	1000 12.73Cd 9.0
max 0° min		1000 53.80Cd 31.5	1000 97.47Cd 81.0	1000 104.3Cd 90.0	1000 87.66Cd 81.0	1000 44.16Cd 31.5	
max 5° min	1000 11.71Cd 9.0	1000 32.42Cd 18.0		1000 70.28Cd 63.0		1000 35.29Cd 18.0	1000 12.42Cd 9.0
max 10° min			1000 28.51Cd* 18.0		1000 34.59Cd* 18.0		

* THE PRESENTED RESULTS REFER ONLY TO THE TESTED SAMPLE.
 * THE PARTIAL REPRODUCTION OF THIS REPORT WITHOUT THE PERMISSION OF IDIADA IS COMPLETELY FORBIDDEN.
 * MEASUREMENT UNCERTAINTY OF THE RESULTS HAS BEEN CALCULATED BY THE LABORATORY.



SAMPLE B

H→ V↓	20°	10°	5°	0°	5°	10°	20°
max 10° min			1000 50.61Cd 18.0		1000 36.11Cd 18.0		
max 5° min	1000 20.74Cd 9.0	1000 77.85Cd 18.0		1000 80.27Cd 63.0		1000 31.09Cd 18.0	1000 13.34Cd 9.0
max 0° min		1000 99.18Cd 31.5	1000 120.1Cd 81.0	1000 102.9Cd 90.0	1000 93.21Cd 81.0	1000 35.34Cd 31.5	
max 5° min	1000 15.88Cd 9.0	1000 84.58Cd 18.0		1000 78.21Cd 63.0		1000 33.06Cd 18.0	1000 16.90Cd 9.0
max 10° min			1000 55.27Cd* 18.0		1000 40.66Cd* 18.0		

* In the case where the lamp is intended to be installed at a mounting height of equal to or less than 750 mm above the ground, the photometric intensity is verified only up to an angle of 5° downwards (2.1.3 Annex 4)

ILLUMINATING SURFACE

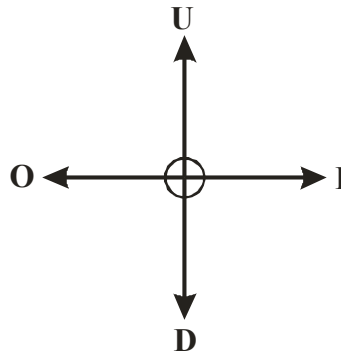

Upper boundary "U" (mm)	Down boundary "D" (mm)	Inner boundary "I" (mm)	Outer boundary "O" (mm)
7	7	21	21

* THE PRESENTED RESULTS REFER ONLY TO THE TESTED SAMPLE.
 * THE PARTIAL REPRODUCTION OF THIS REPORT WITHOUT THE PERMISSION OF IDIADA IS COMPLETELY FORBIDDEN.
 * MEASUREMENT UNCERTAINTY OF THE RESULTS HAS BEEN CALCULATED BY THE LABORATORY.



REPORT No. CN20030833**CONCERNING THE APPROVAL OF FRONT POSITION LAMPS, REAR POSITION LAMPS, STOP LAMPS, DIRECTION INDICATORS AND REAR-REGISTRATION-PLATE ILLUMINATING DEVICES FOR VEHICLES OF CATEGORY L ACCORDING TO REGULATION 50.00 UN**

Manufacturer's name and address : K-Lite (Yuyao) Plastics Co., Ltd.
No.5 Workshop, No.20 Xingye Road,
Yangming Industrial Zone, Yuyao City,
Zhejiang Province, 315400 China (PRC)

Trade mark : K-LITE

Type : M310

Place and date of test report issue : L'Albornar, Santa Oliva (Tarragona)
01/04/2020

CONCLUSIONS: This device **FULFILS** with the prescriptions with regard to the approval of direction indicators of category 12 in application to Regulation No. 50.00 UN, as detailed in the annex to this report.

- * THE PRESENTED RESULTS REFER ONLY TO THE TESTED SAMPLE.
- * THE PARTIAL REPRODUCTION OF THIS REPORT WITHOUT THE PERMISSION OF IDIADA IS COMPLETELY FORBIDDEN.
- * MEASUREMENT UNCERTAINTY OF THE RESULTS HAS BEEN CALCULATED BY THE LABORATORY.

ANNEX TO THE REPORT**CONCERNING THE APPROVAL OF FRONT POSITION LAMPS, REAR POSITION LAMPS, STOP LAMPS, DIRECTION INDICATORS AND REAR-REGISTRATION-PLATE ILLUMINATING DEVICES FOR VEHICLES OF CATEGORY L ACCORDING TO REGULATION 50.00 UN**

Manufacturer's name and address : K-Lite (Yuyao) Plastics Co., Ltd.
No.5 Workshop, No.20 Xingye Road,
Yangming Industrial Zone, Yuyao City,
Zhejiang Province, 315400 China (PRC)

Trade mark : K-LITE

Type : M310

Variants : ---

Sample identification : CN20030833

Lamp : - Single (2.14 (a) R.53)

Light source(s) number and category(ies) : 3 x LEDs

Light source module * : ~~Yes~~—No

Light source module specific identification code: ----

*Strike out what does not apply

MARKING

Marking	CORRECT
---------	----------------

GENERAL SPECIFICATIONS

<p>The requirements contained in sections 5. "General specifications" and 6. "Individual specifications" and in the Annexes referenced in the said sections of Regulations Nos. 53 or 74, and their series of amendments in force at the time of application for the lamp type approval shall apply to this Regulation.</p> <p>The requirements pertinent to each lamp and to the category/ies of vehicle on which the lamp is intended to be installed shall be applied, where its verification at the moment of lamp type approval is feasible.</p>	CORRECT
Vibration endurance	CORRECT

LIGHT SOURCE MODULES

<p>The design of the light source module(s) shall be such as:</p> <p>c) That each light source module can only be fitted in no other position than the designated and correct one and can only be removed with the use of tool(s);</p> <p>d) If there are more than one light source module used in the housing for a device, light source modules having different characteristics cannot be interchanged within the same lamp housing.</p>	NOT APPLICABLE
The light source module(s) shall be tamperproof.	NOT APPLICABLE
A light source module shall be so designed that regardless of the use of tool(s), it shall not be mechanically interchangeable with any replaceable approved light source.	NOT APPLICABLE

CN20030833

IDIADA



* THE PRESENTED RESULTS REFER ONLY TO THE TESTED SAMPLE.
 * THE PARTIAL REPRODUCTION OF THIS REPORT WITHOUT THE PERMISSION OF IDIADA IS COMPLETELY FORBIDDEN.
 * MEASUREMENT UNCERTAINTY OF THE RESULTS HAS BEEN CALCULATED BY THE LABORATORY.

REPLACEABLE LIGHT SOURCE(S)

Light source approved according to Regulation UN No. 37 and/or Regulation UN No. 128.	NOT APPLICABLE
The design of the device shall be such that the light source cannot be fixed in any other position but the correct one.	NOT APPLICABLE
The light source holder shall conform to the characteristics given in IEC Publication 60061.	NOT APPLICABLE

NON-REPLACEABLE FILAMENT LAMP OR LIGHT SOURCE MODULE EQUIPPED WITH NON-REPLACEABLE FILAMENT LAMP(S)

In the case of non-replaceable filament lamp(s) or light source module(s) equipped with non-replaceable filament lamp(s), the applicant shall annex to the type approval documentation a report (by the light source manufacturer indicated in the type approval documentation), acceptable to the Authority responsible for type approval, that demonstrates compliance of these non-replaceable filament lamp(s) with the requirements as specified in paragraph 4.11. of IEC 60809, Edition 3.	NOT APPLICABLE
---	-----------------------

CN20030833

IDIADA



* THE PRESENTED RESULTS REFER ONLY TO THE TESTED SAMPLE.
 * THE PARTIAL REPRODUCTION OF THIS REPORT WITHOUT THE PERMISSION OF IDIADA IS COMPLETELY FORBIDDEN.
 * MEASUREMENT UNCERTAINTY OF THE RESULTS HAS BEEN CALCULATED BY THE LABORATORY.

SEQUENTIAL ACTIVATION OF LIGHT SOURCE(S)

Each light source, after its activation, shall remain lit until the end of the ON cycle.	NOT APPLICABLE
The sequence of activation of the light sources shall produce a signal which proceeds in a uniform progressive manner from inboard towards the outboard edge of the light emitting surface.	NOT APPLICABLE
It shall be one signal with no interruption and no vertical oscillations (e.g. not more than one change of direction along the vertical axis). The distance between two adjacent/tangential distinct parts of the light emitting surface of the sequential direction indicator shall not exceed 50mm, when measured perpendicularly to the reference axis, instead of the values defined in paragraph 5.7.2. of Regulation 48. These interruptions of the signal shall not create any overlap in the vertical axis between the different parts, from inboard towards the outboard of the vehicle, and shall not be used for any other lighting or light signalling functions.	NOT APPLICABLE
The variation shall finish no more than 200 ms after the beginning of the ON cycle. $T_{ON} = \text{--- ms}$	NOT APPLICABLE
The orthogonal projection of the light emitting surfaces of the direction indicator in the direction of the axis of reference shall be circumscribed by a rectangle on a plane normal to the axis of reference and having its longer sides parallel to the H-plane. The ratio of the horizontal to the vertical sides shall not be less than 1.7.	NOT APPLICABLE

CN20030833

IDIADA



* THE PRESENTED RESULTS REFER ONLY TO THE TESTED SAMPLE.
 * THE PARTIAL REPRODUCTION OF THIS REPORT WITHOUT THE PERMISSION OF IDIADA IS COMPLETELY FORBIDDEN.
 * MEASUREMENT UNCERTAINTY OF THE RESULTS HAS BEEN CALCULATED BY THE LABORATORY.

COLORIMETRIC SPECIFICATIONS

AMBER ZONE:

- Limit towards the green: $y \leq x - 0.120$
- Limit towards the red: $y \geq 0.390$
- Limit towards the white: $y \geq 0.790 - 0.670x$

Chromatic co-ordinates (reference axis)	SAMPLE A	SAMPLE B
x	0.5621	0.5637
y	0.4258	0.4256
z	0.0121	0.0107

Test result: The samples tested fulfil with the colorimetric specifications within the field of the light distribution grid defined in the present Regulation. Outside this field no sharp variation of colour is observed.

PHOTOMETRIC SPECIFICATIONS

3. Luminous intensities measured after one minute of operation.

	SAMPLE A	SAMPLE B
Luminous intensity in the angular field specified: $500.0 \geq I(\text{cd}) \geq 0.3$ H = 80° outboard / 20° inboard; V = 15° upwards / 15° downwards H = 80° outboard / 20° inboard; V = 15° upwards / 5° downwards; device installed with the H plane of the lamp with mounting height < 750 mm above the ground	$I_{\text{max}} (\text{cd}) = 116.8$ $I_{\text{min}} (\text{cd}) = 2.557$ CORRECT	$I_{\text{max}} (\text{cd}) = 121.0$ $I_{\text{min}} (\text{cd}) = 2.554$ CORRECT

* THE PRESENTED RESULTS REFER ONLY TO THE TESTED SAMPLE.
 * THE PARTIAL REPRODUCTION OF THIS REPORT WITHOUT THE PERMISSION OF IDIADA IS COMPLETELY FORBIDDEN.
 * MEASUREMENT UNCERTAINTY OF THE RESULTS HAS BEEN CALCULATED BY THE LABORATORY.

SPATIAL LUMINOUS DISTRIBUTION TABLE

SAMPLE A

H→ V↓	20°	10°	5°	0°	5°	10°	20°
max 10° min			500 68.37Cd 10.0		500 58.34Cd 10.0		
max 5° min	500 14.12Cd 5.0	500 61.02Cd 10.0		500 115.6Cd 35.0		500 45.84Cd 10.0	500 12.80Cd 5.0
max 0° min		500 54.10Cd 17.5	500 98.02Cd 45.0	500 104.9Cd 50.0	500 88.16Cd 45.0	500 44.41Cd 17.5	
max 5° min	500 11.78Cd 5.0	500 32.60Cd 10.0		500 70.68Cd 35.0		500 35.49Cd 10.0	500 12.49Cd 5.0
max 10° min			500 28.67Cd* 10.0		500 34.78Cd* 108.0		

SAMPLE B

H→ V↓	20°	10°	5°	0°	5°	10°	20°
max 10° min			500 50.91Cd 10.0		500 36.32Cd 10.0		
max 5° min	500 20.86Cd 5.0	500 78.32Cd 10.0		500 80.75Cd 35.0		500 31.28Cd 10.0	500 13.42Cd 5.0
max 0° min		500 99.76Cd 17.5	500 120.8Cd 45.0	500 103.5Cd 50.0	500 93.76Cd 45.0	500 35.55Cd 17.5	
max 5° min	500 15.97Cd 5.0	500 85.08Cd 10.0		500 78.67Cd 35.0		500 33.26Cd 10.0	500 17.00Cd 5.0
max 10° min			500 55.60Cd* 10.0		500 40.90Cd* 10.0		

* In the case where the lamp is intended to be installed at a mounting height of equal to or less than 750 mm above the ground, the photometric intensity is verified only up to an angle of 5° downwards (2.1.3 Annex 4)

4. Luminous intensities measured after 30 minutes of operation.

	SAMPLE A	SAMPLE B
Luminous intensity in the angular field specified: $500.0 \geq I(\text{cd}) \geq 0.3$ H = 80° outboard / 20° inboard; V = 15° upwards / 15° downwards H = 80° outboard / 20° inboard; V = 15° upwards / 5° downwards: device installed with the H plane of the lamp with mounting height < 750 mm above the ground	$I_{\text{max}} (\text{cd}) = 116.1$ $I_{\text{min}} (\text{cd}) = 2.543$ CORRECT	$I_{\text{max}} (\text{cd}) = 120.3$ $I_{\text{min}} (\text{cd}) = 2.539$ CORRECT

SPATIAL LUMINOUS DISTRIBUTION TABLE

SAMPLE A

H→ V↓	20°	10°	5°	0°	5°	10°	20°
max 10° min			500 67.99Cd 10.0		500 58.02Cd 10.0		
max 5° min	500 14.04Cd 5.0	500 60.67Cd 10.0		500 115.0Cd 35.0		500 45.58Cd 10.0	500 12.73Cd 5.0
max 0° min		500 53.80Cd 17.5	500 97.47Cd 45.0	500 104.3Cd 50.0	500 87.66Cd 45.0	500 44.16Cd 17.5	
max 5° min	500 11.71Cd 5.0	500 32.42Cd 10.0		500 70.28Cd 35.0		500 35.29Cd 10.0	500 12.42Cd 5.0
max 10° min			500 28.51Cd* 10.0		500 34.59Cd* 10.0		

* THE PRESENTED RESULTS REFER ONLY TO THE TESTED SAMPLE.
 * THE PARTIAL REPRODUCTION OF THIS REPORT WITHOUT THE PERMISSION OF IDIADA IS COMPLETELY FORBIDDEN.
 * MEASUREMENT UNCERTAINTY OF THE RESULTS HAS BEEN CALCULATED BY THE LABORATORY.



SAMPLE B

H→ V↓	20°	10°	5°	0°	5°	10°	20°
max 10° min			500 50.61Cd 10.0		500 36.11Cd 10.0		
max 5° min	500 20.74Cd 5.0	500 77.85Cd 10.0		500 80.27Cd 35.0		500 31.09Cd 10.0	500 13.34Cd 5.0
max 0° min		500 99.18Cd 17.5	500 120.1Cd 45.0	500 102.9Cd 50.0	500 93.21Cd 45.0	500 35.34Cd 17.5	
max 5° min	500 15.88Cd 5.0	500 84.58Cd 10.0		500 78.21Cd 35.0		500 33.06Cd 10.0	500 16.90Cd 5.0
max 10° min			500 55.27Cd* 10.0		500 40.66Cd* 10.0		

*In the case where the lamp is intended to be installed at a mounting height of equal to or less than 750 mm above the ground, the photometric intensity is verified only up to an angle of 5° downwards (2.1.3 Annex 4)

ILLUMINATING SURFACE

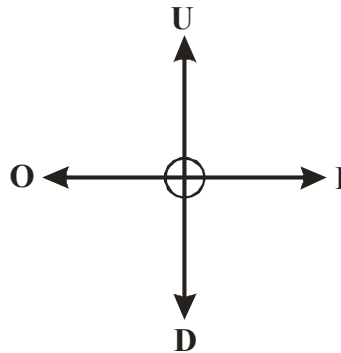

Upper boundary "U" (mm)	Down boundary "D" (mm)	Inner boundary "I" (mm)	Outer boundary "O" (mm)
7	7	21	21

Test place: Ningbo China
Test date: 30/03/2020

Joan Fonts Sala
TEST ENGINEER

* THE PRESENTED RESULTS REFER ONLY TO THE TESTED SAMPLE.
* THE PARTIAL REPRODUCTION OF THIS REPORT WITHOUT THE PERMISSION OF IDIADA IS COMPLETELY FORBIDDEN.
* MEASUREMENT UNCERTAINTY OF THE RESULTS HAS BEEN CALCULATED BY THE LABORATORY.

