

## r.LiNK Video inserter

Compatible with Renault vehicles with R-LINK2 Infotainment  
and 7inch or 8.7 inch monitor



**Video-inserter with 2 video inputs,  
rear-view camera input and CAN control**

### Product features

- Video-inserter for factory-infotainment monitors
- 2 CVBS video-inputs for after-market devices (e.g. DVD-Player, DVB-T tuner)
- FBAS Rear-view camera video-input
- Automatic switching to rear-view camera input on engagement of the reverse gear
- Video-in-motion in drive mode (ONLY for connected video-sources)
- AV-inputs PAL/NTSC compatible

## Contents

### 1. Prior to installation

- 1.1. Delivery contents
- 1.2. Checking the compatibility of vehicle and accessories
- 1.3. Boxes and connectors
  - 1.3.1. Video-Interface
- 1.4. Settings of the 8 Dip switches (black)
  - 1.4.1.1. Enabling the interface's video inputs (dips 2-3)
  - 1.4.1.2. Rear-view camera setting (dip 5)
  - 1.4.1.3. Monitor adjustments (dip 8)
- 1.5. Settings of the 4 Dip switches (CAN function – red)

### 2. Installation

- 2.1. Place of installation
- 2.2. Connection schema
- 2.3. Connection to the factory monitor
  - 2.3.1. ....7inch monitors with 8pin connector
  - 2.3.2. ....8,7inch monitors with 24pin connector
- 2.4. Analog power supply for the video interface
- 2.5. Connecting the video-sources
  - 2.5.1. Audio insertion
  - 2.5.2. ....After-market rear-view camera
    - 2.5.2.1. Case 1: Interface receives the reverse gear signal
    - 2.5.2.2. Case 2: Interface does not receive the reverse gear signal
- 2.6. Connecting video-interface and keypad
- 2.7. Picture settings

### 3. Interface operation

- 3.1. By factory infotainment button
- 3.2. By external keypad

### 4. Specifications

### 5. FAQ – Trouble Shooting-Interface functions

### 6. Technical support

## Legal Information

By law, watching moving pictures while driving is prohibited, the driver must not be distracted. We do not accept any liability for material damage or personal injury resulting, directly or indirectly, from installation or operation of this product. Apart from using this product in an unmoved vehicle, it should only be used to display fixed menus or rear-view-camera video when the vehicle is moving (for example the MP3 menu for DVD upgrades).

Changes/updates of the vehicle's software can cause malfunctions of the interface. Up to one year after purchase we offer free software-updates for our interfaces. To receive a free update, the interface has to be sent in at own cost. Wages for de-and reinstallation and other expenditures involved with the software-updates will not be refunded.

## 1. Prior to installation

Read the manual prior to installation. Technical knowledge is necessary for installation. The place of installation must be free of moisture and away from heat sources.

### 1.1. Delivery contents

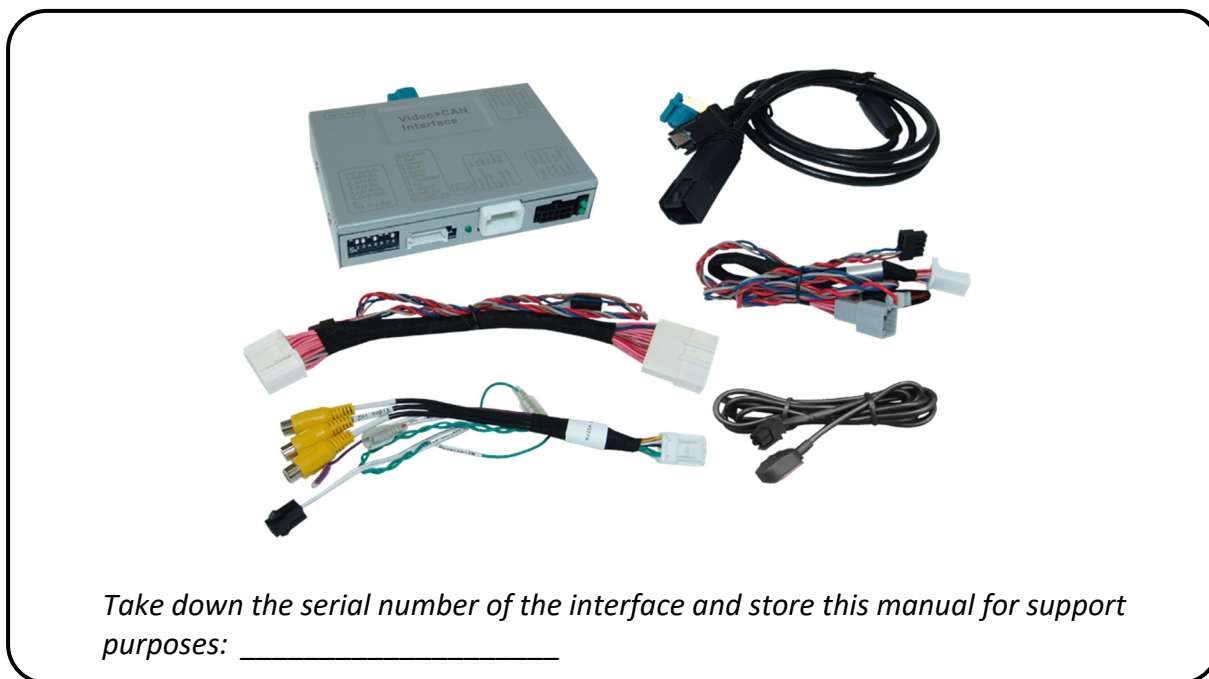

## 1.2. Checking the compatibility of vehicle and accessories

Requirements		
Brand	Compatible vehicles	Compatible systems
<b>Renault</b>	Espace from about 2015-, Kadjar from about 2015-, Megane from about 2016-, Scenic from about 2016-. Talisman from about 2015- and other vehicles with	R-LINK2 with 7inch or 8.7inch monitor
<b>Limitations</b>		
<i>Video only</i>	The interface inserts ONLY video signals into the infotainment. For inserting Audio signals either the possibly existing factory audio-AUX-input or a FM-modulator can be used. If 2 audio sources shall be connected to the infotainment, an additional electronic is necessary to switch them.	
<i>Factory rear-view camera</i>	Automatically switching-back from inserted video to factory rear-view camera is only possible while the reverse gear is engaged. To delay the switch-back an additional electronic part is required.	
<i>Factory PDC</i>	With connecting the interface, the former PDC graphics won't apply anymore. Acoustic signals will still be present.	
<i>Guidelines</i>	The interface doesn't generate guidelines.	

## 1.3. Boxes and connectors

### 1.3.1. Video Interface

The video-interface converts the video signals of connected after-market sources in a factory monitor compatible picture signal which is inserted in the factory monitor, by using separate trigger options. Further it reads the vehicle's digital signals out of the vehicle's CAN-bus and converts them for the video interface.

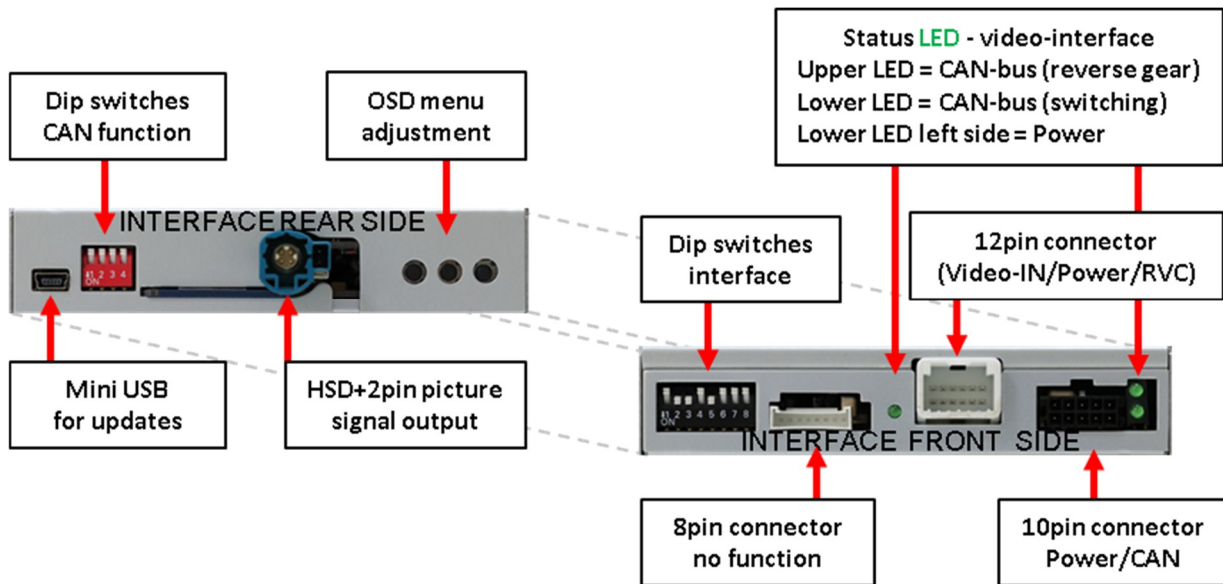

### 1.4. Settings of the 8 Dip switches (black)

Some settings must be selected by the dip-switches on the video interface. Dip position down is ON and position up is OFF.



Dip	Function	ON (down)	OFF (up)
1	No function		set to OFF
2	CVBS Video 1-input	enabled	disabled
3	CVBS Video 2-input	enabled	disabled
4	No function		Set to OFF
5	Rear-view cam type	after-market	factory or none
6	No function		Set to OFF
7	No function		Set to OFF
8	Monitor size	7inch monitor	8,7inch monitor

**After each Dip-switch-change a power-reset of the Can-box has to be performed!**

See the following chapters for detailed information.

## 1.4.1.1. Enabling the interface's video inputs (dips 2-3)

Only the enabled video inputs can be accessed by switching through the interface's video sources. It is recommended to enable only the required inputs. So the disabled inputs will be skipped while switching through the video interfaces inputs.

## 1.4.1.2. Rear-view camera setting (dip 5)

If set to OFF, the interface switches to factory L picture while the reverse gear is engaged to display factory rear-view camera.

If set to ON, the interface switches to its rear-view camera input „Camera-IN“ while the reverse gear is engaged.

## 1.4.1.3. Monitor adjustments (dip 8)

Dip switch 8 changes the monitor adjustments. For the 7inch monitor the dip switch setting has to be ON and for the 8,7inch monitor the dip switch setting has to be OFF.

Size of monitor	Dip 8
7inch	ON
8,7inch	OFF

**Note:** Dip 1, 4, 6 and 7 are out of function and have to be set to **OFF**.

## 1.5. Settings of the 4 Dip switches (CAN functions – red)

All 4 dip-switches of the video interface for LiNK2 infotainments have to be set to OFF.



Dip position down is ON and position up is OFF.

vehicle/infotainment	Dip 1	Dip 2	Dip 3	Dip 4
Alle Fahrzeuge	OFF	OFF	OFF	OFF

**After each Dip-switch-change, a power-reset of the Can-box has to be performed!**

## 2. Installation

**To install the interface, first switch off the ignition and disconnect the vehicle's battery. Please read the owner's manual of the car, regarding the battery's disconnection! If required, enable the car's Sleep-mode (hibernation mode)**

**In case the sleep-mode does not succeed, the disconnection of the battery can be done with a resistor lead.**

**If the necessary stabilized power supply for the interface is not taken directly from the battery, the chosen connection has to be checked for being constantly stable.**

**The interface needs a permanent 12V source!**

Before a final installation, we recommend a test-run to ensure the compatibility of the vehicle and the interface. Due to changes in the production of the vehicle manufacturer there's always a possibility of incompatibility.

### 2.1. Place of installation

The video interface is performed to be connected behind the vehicle's monitor.

## 2.2. Connection schema



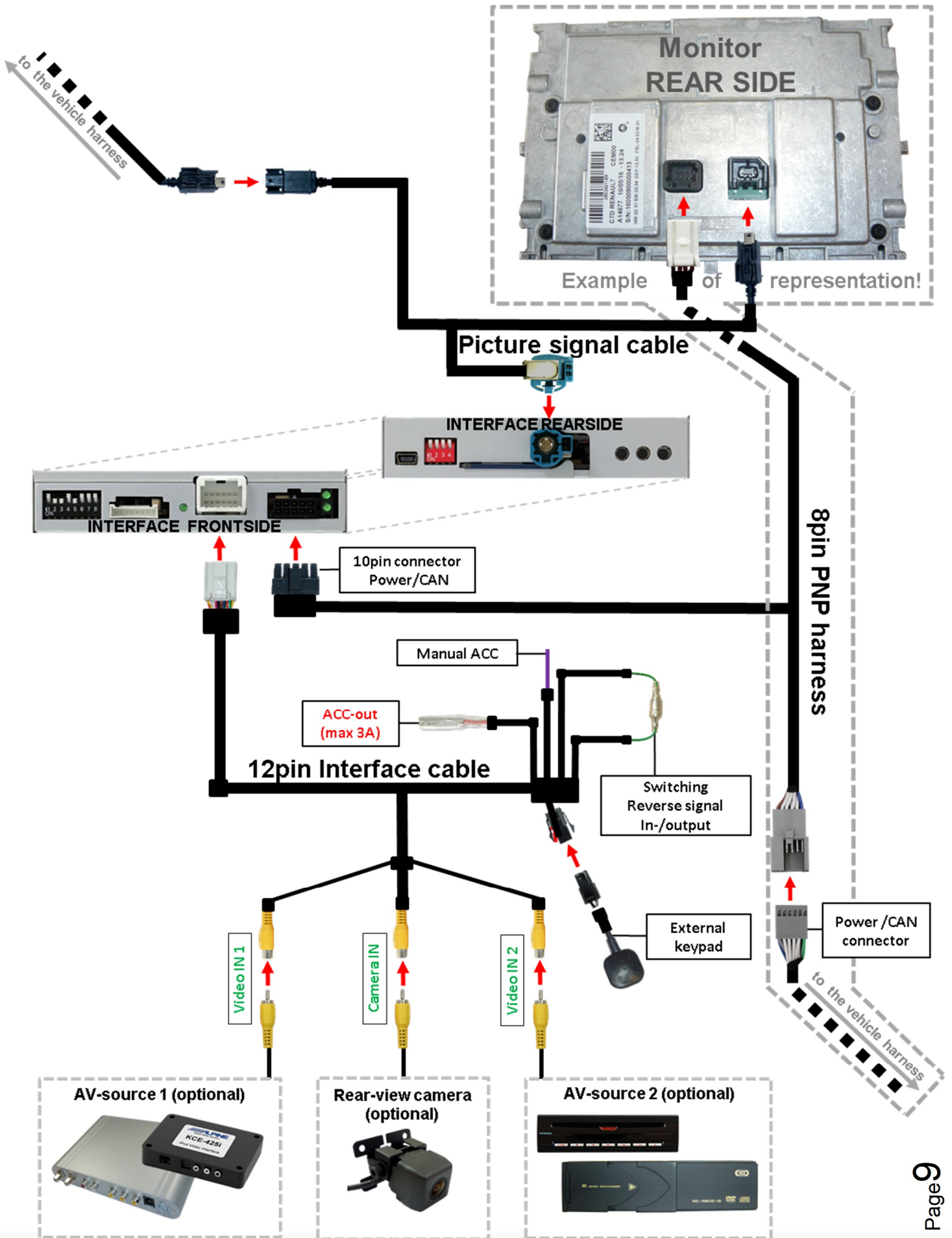

## 2.3. Connections to the factory monitor

Note: 2 different harnesses for 7" (8pin) and 8,7" (24pin) enclosed!

### 2.3.1. 7inch monitors with 8pin connection

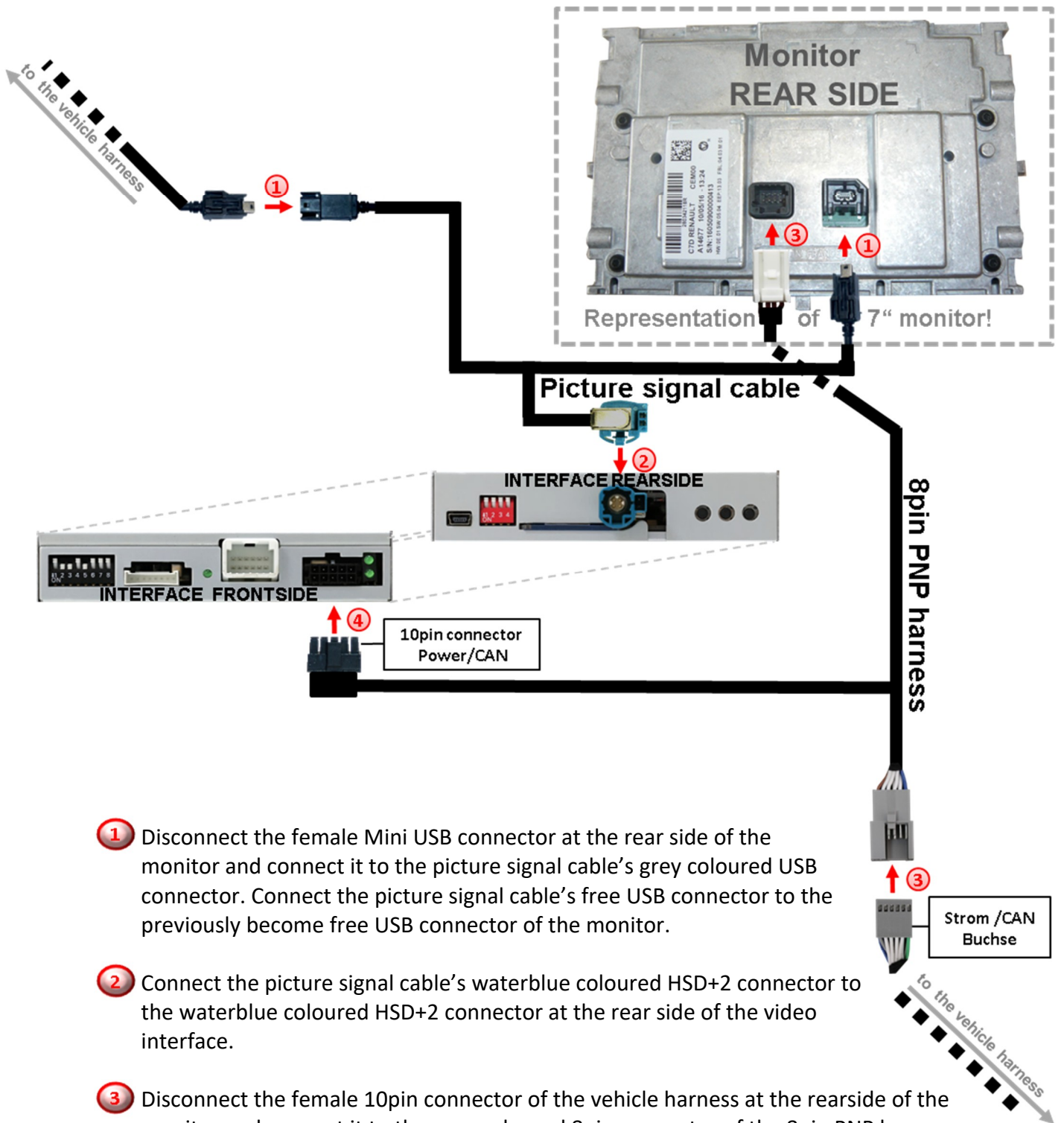

- 1 Disconnect the female Mini USB connector at the rear side of the monitor and connect it to the picture signal cable's grey coloured USB connector. Connect the picture signal cable's free USB connector to the previously become free USB connector of the monitor.
- 2 Connect the picture signal cable's waterblue coloured HSD+2 connector to the waterblue coloured HSD+2 connector at the rear side of the video interface.
- 3 Disconnect the female 10pin connector of the vehicle harness at the rear side of the monitor and connect it to the grey coloured 8pin connector of the 8pin PNP harness. Connect the free white coloured female 8pin connector of that harness to the previously become free 8pin connector at the rear side of the monitor.

4

Connect the female black coloured 10pin Power / CAN connector of the 8pin PNP harness to the 10pin connector at the front side of the video interface.

## 2.3.2. 8,7inch monitors with 24pin connection

For vehicles with 8,7inch monitor and 24pin connection, the included 24pin PNP harness has to be used instead of the 10pin PNP harness.

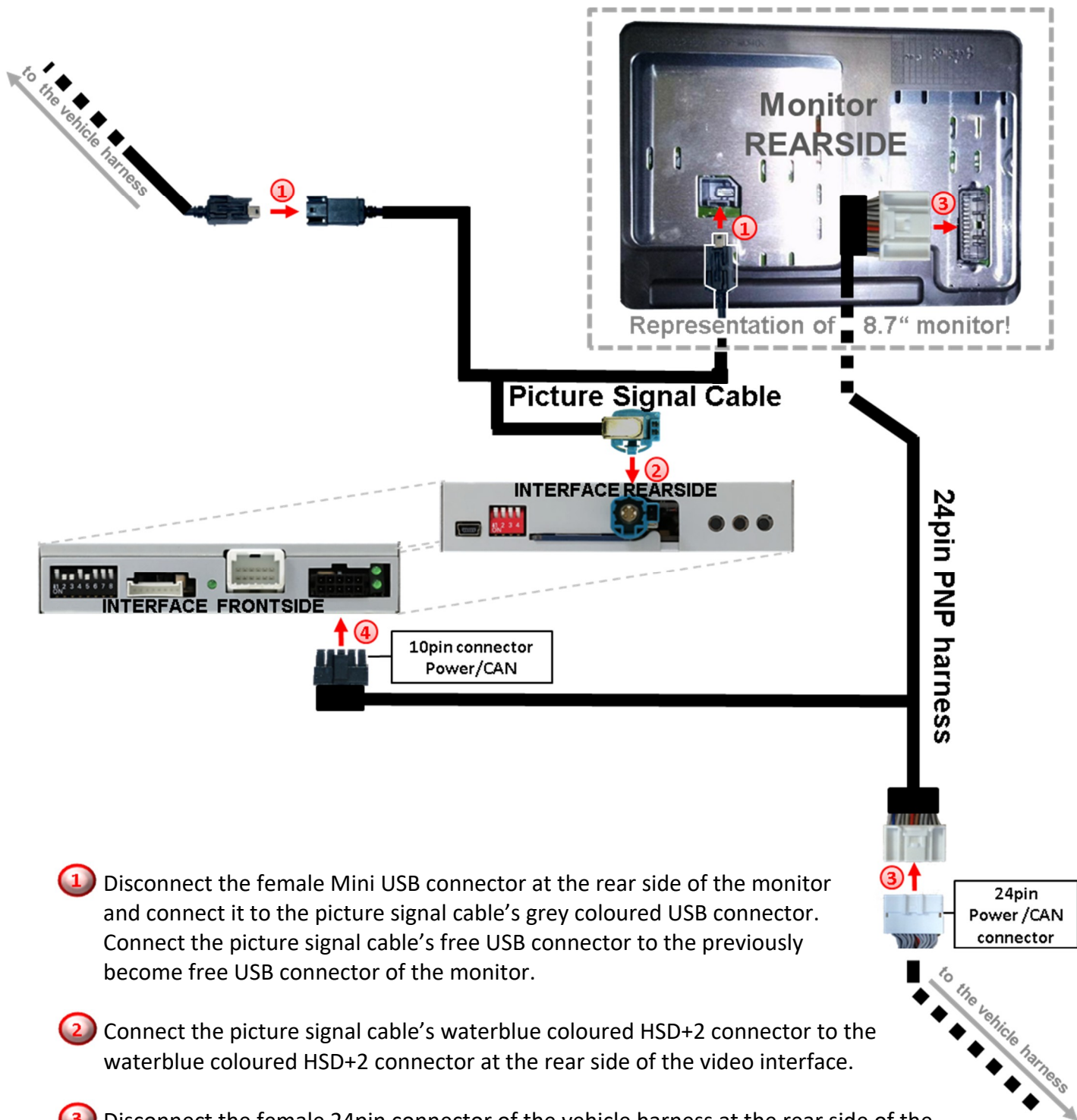

- ① Disconnect the female Mini USB connector at the rear side of the monitor and connect it to the picture signal cable's grey coloured USB connector. Connect the picture signal cable's free USB connector to the previously become free USB connector of the monitor.
- ② Connect the picture signal cable's waterblue coloured HSD+2 connector to the waterblue coloured HSD+2 connector at the rear side of the video interface.
- ③ Disconnect the female 24pin connector of the vehicle harness at the rear side of the monitor and connect it to the white coloured 24pin connector of the 24pin PNP harness. Connect the free white coloured female 24pin connector of that harness to the previously become free 24pin connector at the rear side of the monitor.
- ④ Connect the female black coloured 10pin Power / CAN connector of the 24pin PNP harness to the 10pin connector at the front side of the video interface.

## 2.4. Analog power supply for the video interface

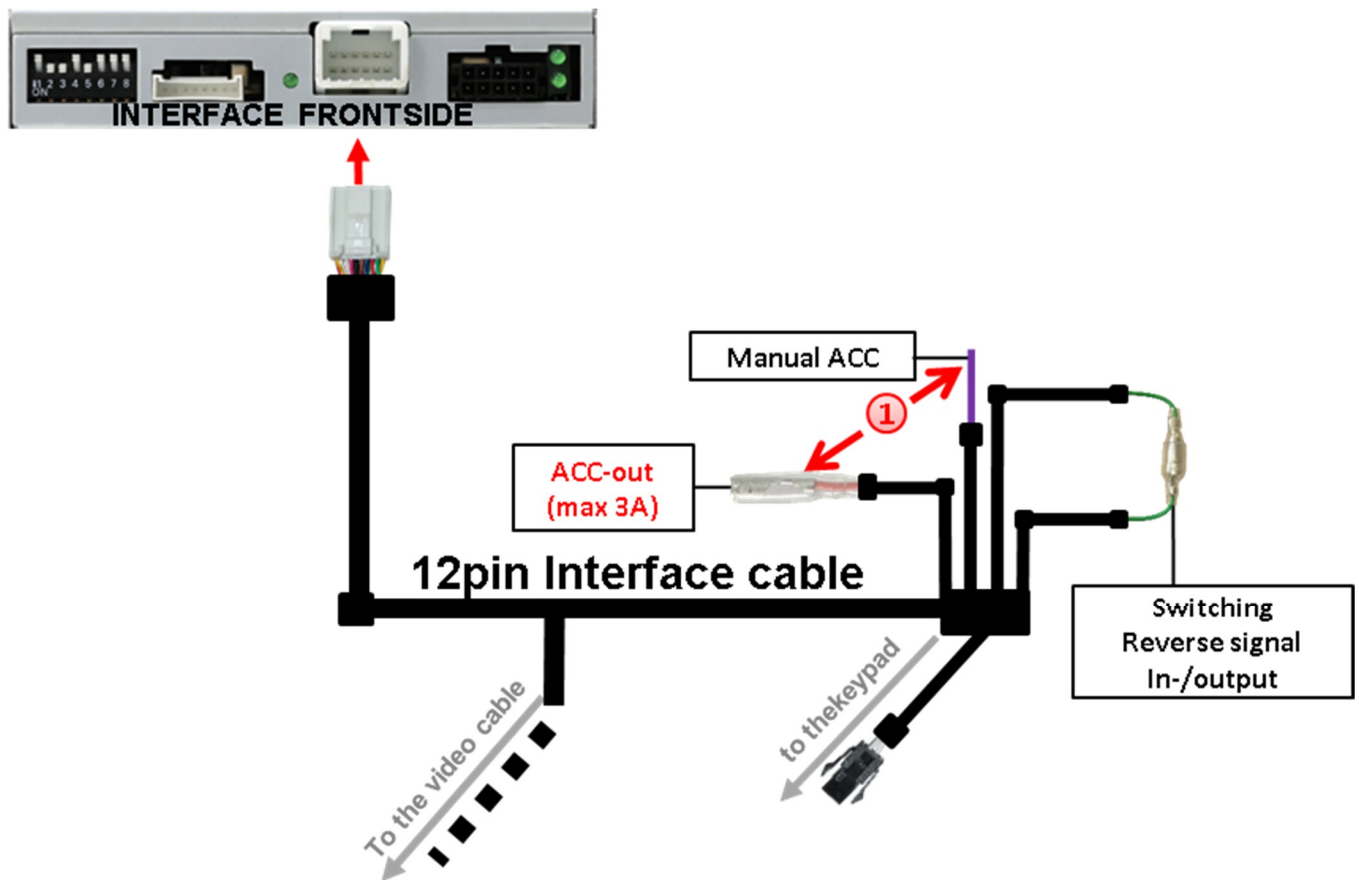

If, after connecting the PNP harness, no interface LED lightens up while the ignition is turned on, the single red wire **ACC-out (max 3A)** and the purple coloured wire **Manual ACC** of the 12pin interface cable both have to be connected additionally to **S-contact terminal 86s +12V** (e.g. glove compartment illumination).

## 2.5. Connecting video sources

It is possible to connect an after-market rear-view camera and two more AV sources to the video-interface.

Before the final installation, we recommend a test-run of the interface. Due to changes in production of the vehicle manufacturer, there's always the possibility of incompatibility.

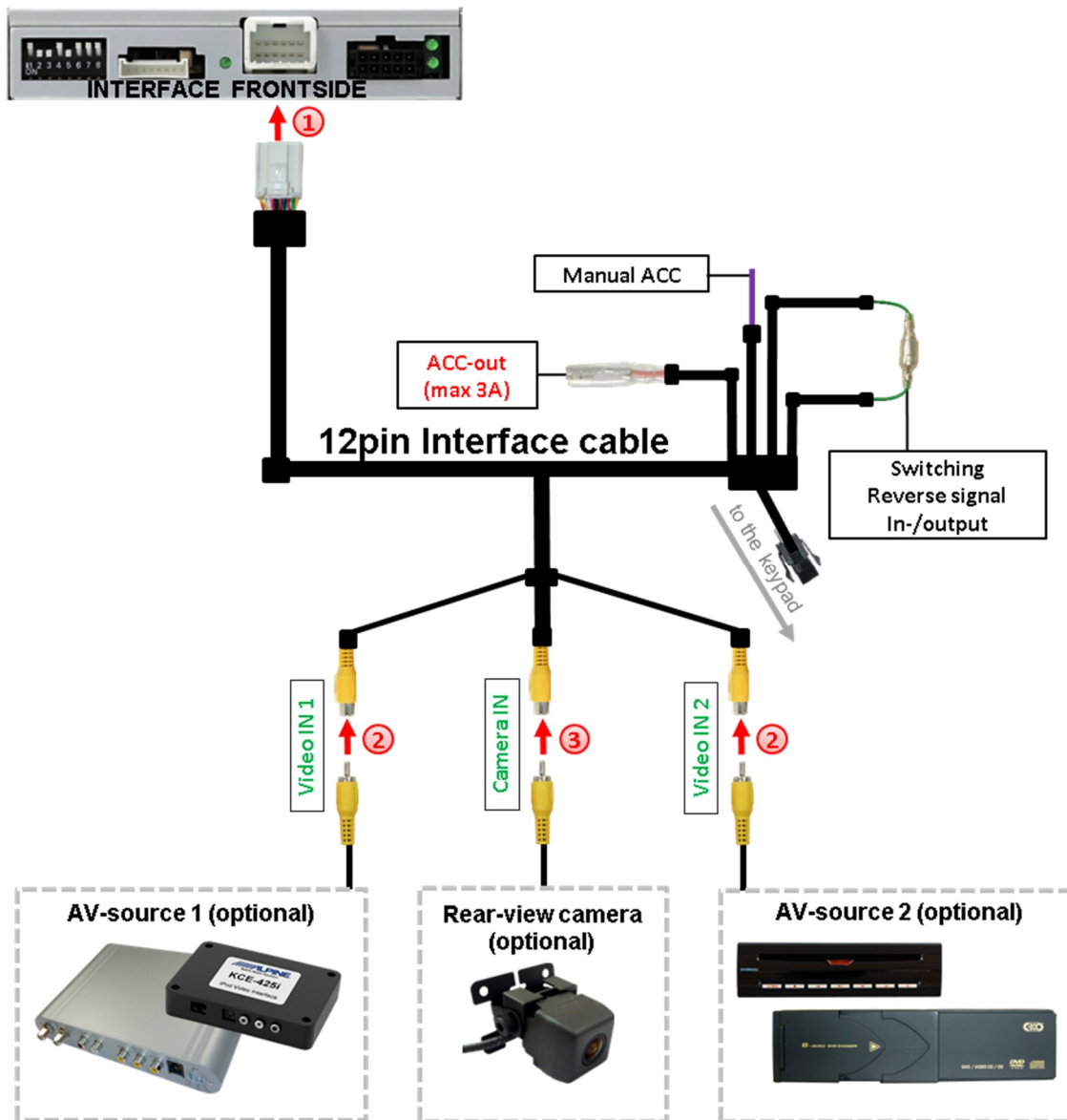

- 1 Connect the female 12pin connector of the 12pin interface cable to the male 12pin connector of the video-interface.
- 2 Connect the video RCA connectors of additional AV sources to the female RCA connectors „Video IN 1” und “Video IN 2”.
- 3 Connect the video RCA connector of the rear-view camera to the female RCA connector “Camera-IN” of the 12pin interface cable.

(see also “After-market rear-view camera”).

## 2.5.1. Audio-insertion

This interface is only able to insert video signals into the factory infotainment. If an AV-source is connected, the audio insertion has to be done by the factory audio AUX input or an FM-modulator. The inserted video-signal can be activated simultaneously to each audio-mode of the factory infotainment.

If 2 AV sources shall be connected to the infotainment, additional electronic is necessary to switch the audio signals.

## 2.5.2. After-market rear-view camera

Some vehicles have a different reverse gear code on the CAN-bus which the video-interface is not compatible with. Therefore, there are two different ways of installation. If the video interface receives a signal of the reverse gear, the green wire **“Reverse-OUT”** of the 20pin cable should carry +12V while the reverse gear is engaged.

**Note:** Do not forget to set video interface’s dip5 to ON before testing.

### 2.5.2.1. Case 1: Interface receives the reverse gear signal

If the CAN-bus interface receives +12V on the green wire of the 20pin cable when reverse gear is engaged, it will automatically be switched to the rear-view camera input **“Camera IN”** while reverse gear is engaged.

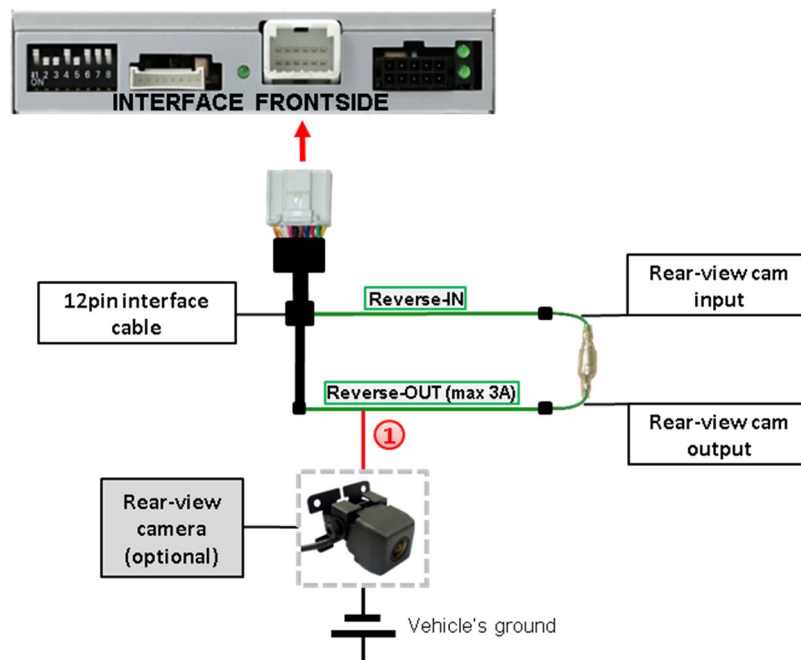

- 1 Die 12V Stromversorgung für die After-Market Rückfahrkamera (max. 3A) erfolgt durch Anschließen an die grüne Leitung des 12 Pin Interface Kabels um einen unnötigen Dauerbetrieb der Kameraelektronik zu vermeiden.



Die beiden grünen Kabel „Reverse-IN“ und „Reverse-OUT“ müssen für den Betrieb miteinander verbunden bleiben.

## 2.5.2.2. Case 2: Interface does not receive the reverse gear signal

If the video interface does not deliver +12V on the green wire of the 20pin cable when reverse gear is engaged (not all vehicles are compatible), an external switching signal from the reverse gear light is required. As the reverse gear light's power supply isn't voltage-stable all the time, an ordinary open relay (e.g. AC-RW-1230 with wiring AC-RS5) or filter (e.g. AC-PNF-RVC) is required. The diagram below shows the connection type of the relay.

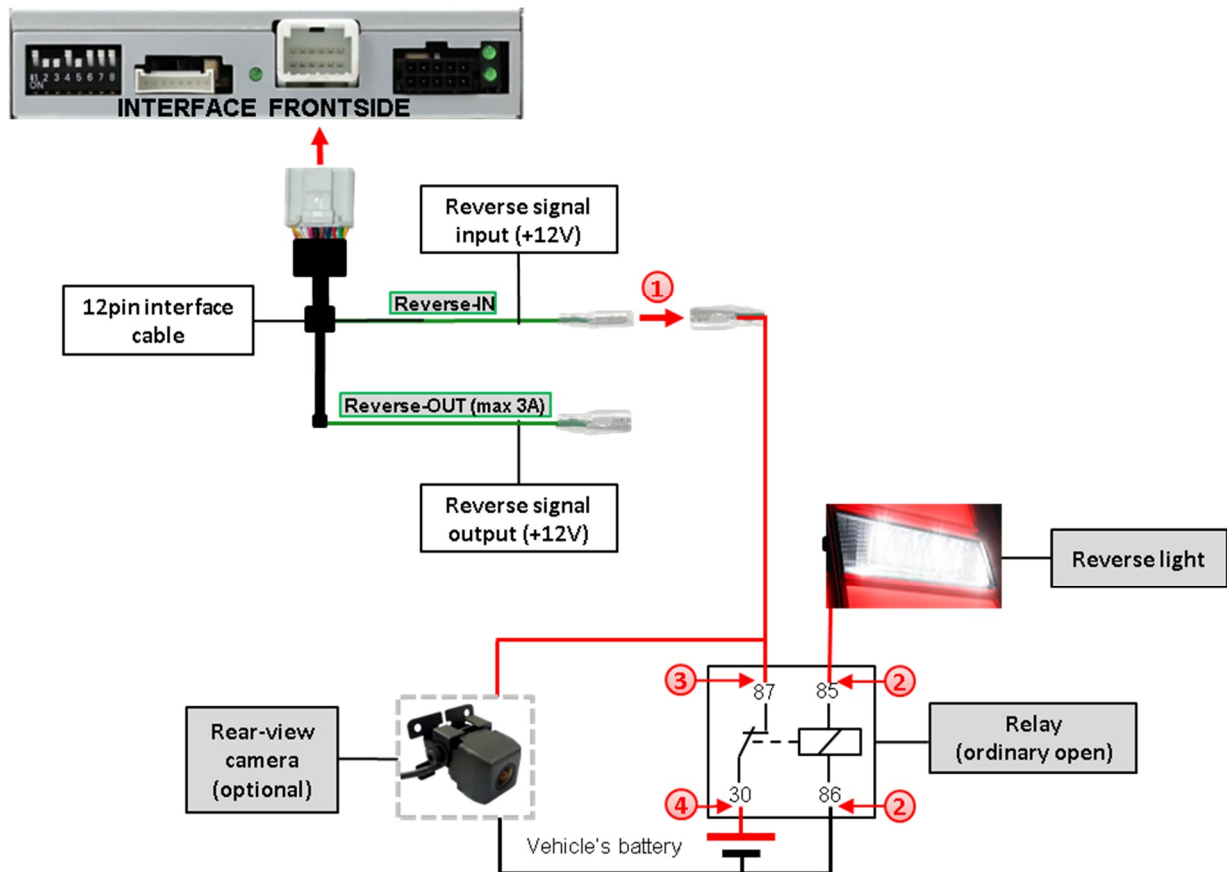

- 1 Disconnect the green cable's preconnected male- and female connectors of the 12pin interface cable and connect the green input cable "Reverse-IN" to the output connector (87) of the relay.

**Note:** Not least to avoid short circuits, the best solution should be, to crimp a male 4mm connector to the relay's output cable and connect it to the green cable's female 4mm connector. The output-cable "Reverse-OUT" remains disconnected as it's out of function.

- 2 Connect the Reverse light's power-cable to coil (85) and the vehicle's ground to coil (86) of the relay.
- 3 Connect the output connector (87) of the relay to the rear-view camera's power-cable, like you did it with the green "Reverse-IN" cable before.

- 4 Connect permanent power / 12V to the relay's input connector (30).

## 2.6. Connecting video-interface and keypad

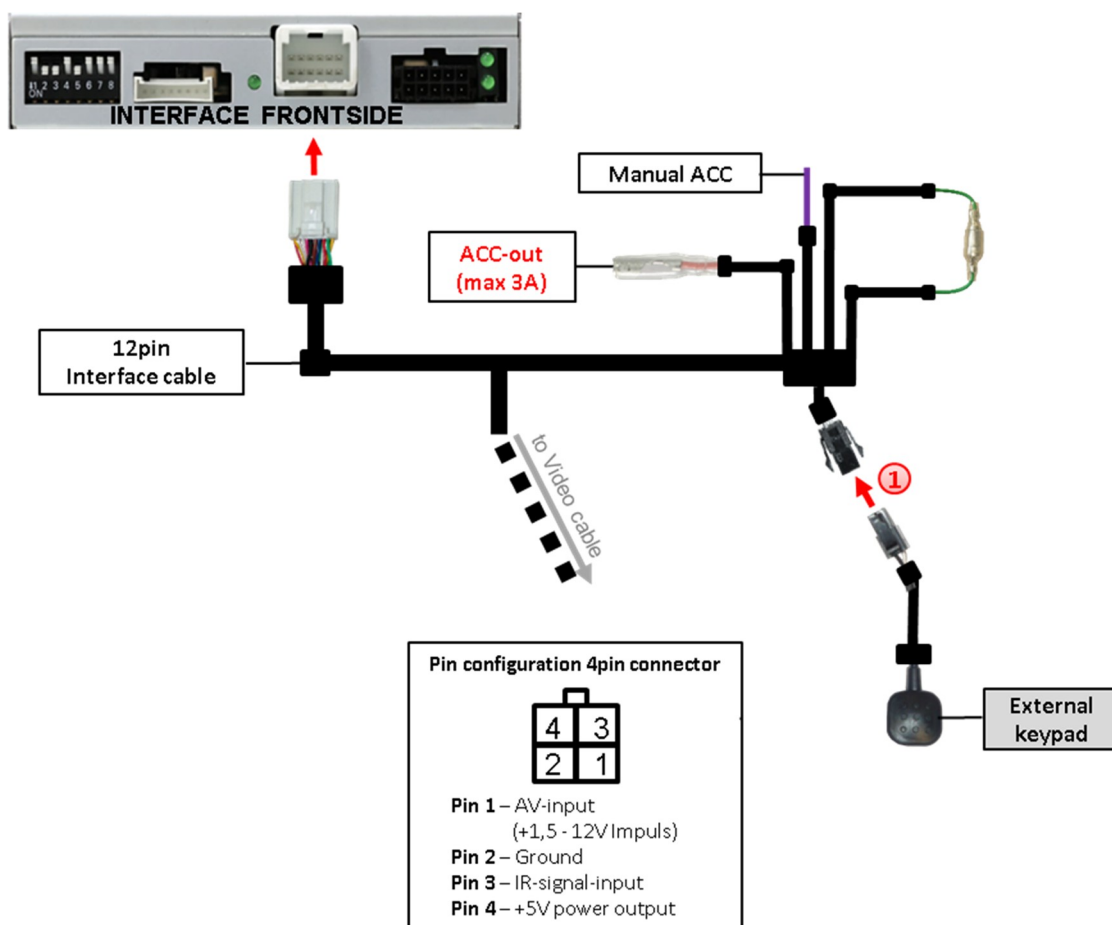

- 1 Connect the female 4pin connector of the keypad to the male 4pin connector of the 20pin interface cable.

**Note:** Regardless if it'll be used or not, the external keypad should always be connected! In case of non-using, it should be invisibly hidden together with the video interface.

## 2.7. Picture settings

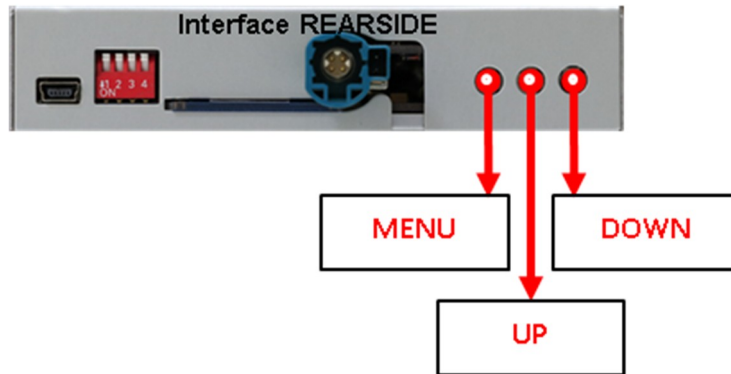

The picture settings are adjustable by the 3 push-buttons on the video-interface. Press the MENU button to open the OSD settings menu or to switch to the next menu item. Press UP and DOWN to change the selected value. The buttons are placed inside in the housing to avoid accidental changes during or after the installation. Picture settings must be done separately for Video1 and Video2 while the corresponding input is selected and visible on the monitor.

**Note:** The OSD menu is only shown when a working video source is connected to the selected video-input of the interface.

The following settings are available:

- Contrast
- Brightness
- Saturation
- Position H (horizontal)
- Position V (vertical)
- IR-AV1/2 (no function)
- Guide L/R (no function)
- UI-CNTRL (guide lines ON/OFF)
- Size H/V (picture size horizontal/vertical)

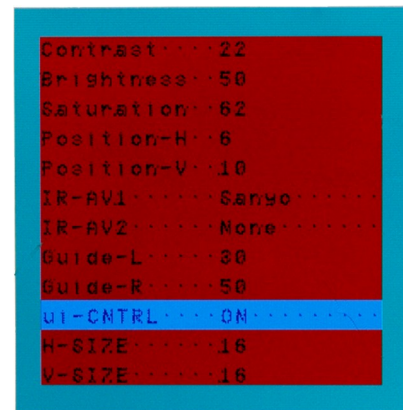

## 3. Interface operation

### 3.1. By factory infotainment button



Pressing the “LIST” button switches the input from the factory video to the inserted video sources. If all inputs are activated by dip switch settings, the order is the following:

*Factory video → Video IN 1 → Video IN 2 → factory video*

Each press will switch to the next enabled input. Inputs which are not enabled will be skipped.

**Switchover by vehicle buttons isn't possible in all vehicles. In some vehicles the external keypad has to be used.**

### 3.2. By external keypad

Alternatively or additionally to the factory infotainment buttons the interface's external keypad can be used to switch the enabled inputs.

## 4. Specifications

BATT/ACC range	7V - 25V
Stand-by power drain	15mA
Power	250mA @12V
Video input	0.7V - 1V
Video input formats	PAL/NTSC
Temperature range	-40°C to +85°C
Dimensions video-box	118 x 24 x 103 mm (W x H x D)

## 5. FAQ – Trouble shooting Interface functions

For any troubles which may occur, check the following table for a solution before requesting support from your vendor.

Symptom	Reason	Possible solution
No picture/black picture (factory picture).	Not all connectors have been reconnected to factory head-unit or monitor after installation.	Connect missing connectors.
	No power on CAN-bus box (all LED CAN-bus box are off).	Check power supply of CAN-bus box. Check CAN-bus connection of CAN-bus box.
	CAN-bus box connected to CAN-bus in wrong place.	Refer to the manual where to connected to the CAN-bus. If not mentioned, try another place to connect to the CAN-bus.
	No power on video-interface (all LED video-interface are off).	Check whether CAN-bus box delivers +12V ACC on red wire output of 8pin to 6pin cable. If not cut wire and supply ACC +12V directly to video-interface.
No picture/black picture/white picture (inserted picture) but factory picture is OK.	No picture from video source.	Check on other monitor whether video source is OK.
	No video-source connected to the selected interface input.	Check settings dips 1 to 3 of video interface which inputs are activated and switch to corresponding input(s).
	LVDS cables plugged in wrong place.	Double-check whether order of LVDS cables is exactly connected according to manual. Plugging into head-unit does not work when the manual says to plug into monitor and vice versa.
Inserted picture totally wrong size or position.	Wrong monitor settings of video-interface.	Try different combinations of dips 7 and 8 of video-interface. Unplug 6pin power after each change.
Inserted picture double or 4 times on monitor.		
Inserted picture distorted, flickering or running vertically.	Video sources output set to AUTO or MULTI which causes a conflict with the interfaces auto detection.	Set video source output fixed to PAL or NTSC. It is best to set all video sources to the same standard.
	If error occurs only after source switching: Connected sources are not set to the same TV standard.	Set all video sources to the same standard.
	Some interfaces can only handle NTSC input.	Check manual whether there is a limitation to NTSC mentioned. If yes, set source fixed to NTSC output.
Inserted picture b/w.	Picture settings have not been adjusted.	Use the 3 buttons and the interface's OSD to adjust the picture settings for the corresponding video input.
Inserted picture qual. bad.		
Inserted picture size slightly wrong.		
Inserted picture position wrong.		
Camera input picture flickers.	Camera is being tested under fluorescent light which shines directly into the camera.	Test camera under natural light outside the garage.
Camera input picture is bluish.	Protection sticker not removed from camera lens.	Remove protection sticker from lens.





Symptom	Reason	Possible solution
Camera input picture black.	Camera power taken directly from reverse gear lamp.	Use relay or electronics to "clean" reverse gear lamp power. Alternatively, if CAN-bus box is compatible with the vehicle, camera power can be taken from green wire of 6pin to 8pin cable.
Camera input picture has distortion.		
Camera input picture settings cannot be adjusted.	Camera input picture settings can only be adjusted in AV2 mode.	Set dip 3 of video-interface to ON (if not input AV2 is not already activated) and connect the camera to AV2. Switch to AV2 and adjust settings. Reconnect camera to camera input and deactivate AV2 if not used for other source.
Graphics of a car in camera input picture.	Function PDC is ON in the interface OSD.	In compatible vehicles, the graphics will display the factory PDC distance. If not working or not wanted, set interface OSD menu item UI-CNTRL to ALLOFF.
Chinese signs in camera input picture	Function RET or ALL is ON (function for Asian market) in the interface OSD.	Set interface OSD menu item UI-CNTRL to ALLOFF or PDCON.
Not possible to switch video sources by OEM button.	CAN-bus interface does not support this function for vehicle.	Use external keypad or cut white wire of 6pin to 8pin cable and apply +12V impulses for AV-switching.
Not possible to switch video sources by external keypad.	Pressed too short.	For video source switching a longer press of about 2.5 seconds is required.
	SW-version of interface does not support external keypad.	Use OEM-button or cut white wire of 6pin to 8pin cable and apply +12V impulses for AV-switching.
Interface does not switch to camera input when reverse gear is engaged.	CAN-bus interface does not support this function for the vehicles.	Cut the green wire of the 6pin to 8pin cable and apply +12V constant from reverse gear-lamp signal. Use relay to "clean" R-gear lamp power.
Interface switches video-sources by itself.	CAN-bus interface compatibility to vehicle is limited.	Cut the grey wire of 6pin to 8pin and isolate both ends. If problem still occurs, additionally cut the white wire of 6pin to 8pin cable and isolate both ends.

## 6. Technical Support

Please note that direct technical support is only available for products purchased directly. For products bought from other sources, contact your vendor for technical support.

 10R-03 5384

Made in China



 RoHS