

**VCA Headquarters**

1 The Eastgate Office Centre
Eastgate Road
Bristol, BS5 6XX
United Kingdom

Switchboard: +44 (0) 117 951 5151
Direct line: +44 (0) 117 952
Main Fax: +44 (0) 117 952 4103
Email: enquiries@vca.gov.uk
Web: www.vca.gov.uk

Your Reference:

Date: 14 APRIL 2011

Dear

MANUFACTURER OR ACCREDITED AGENT: DONG GUAN JIA HONG AUTO ACCESSORIES CO., LTD.

ECE REGULATION/EEC DIRECTIVE: ECE R7.02, ECE R87.00

Job No.	Vehicle Type/Component	Approval No.	Index Rev. No.
KSL218333	JS-11309 / Grouped lamp	E11 7R-025652 E11 87R-005652	-

1. This vehicle type/component has been tested and meets the requirements of the above ECE Regulation/EEC Directive. I enclose a set of approval documents, comprising the approval, test report and your documentation duly authenticated.

2. If you think there are any errors in the enclosed package, please contact Andrew Meadows, telephone 0117 952 4187, e-mail andrew.meadows@vca.gov.uk Patricia Britton, telephone 0117 952 4171, e-mail pat.britton@vca.gov.uk immediately. Please be aware that from the date of issue we have a three week holding period, any corrections required after this time will need to be corrected via an extension, index revision or correction 1 certificate, as appropriate.

ROAD TRAFFIC ACT 1988 - SECTION 80

3. The Secretary of State for Transport authorises, under section 80 of the Road Traffic Act 1988, the above manufacturer or accredited agent to apply to the motor vehicle type/part specified, the appropriate mark designated in the Motor Vehicles (Designation of Approval Marks) Regulations 1979, as amended. The conditions attached to this authorisation are set out overleaf.

4. If this approval/extension results in a change being needed to a vehicle information document issued under the goods vehicle or passenger car national type approval scheme, you should notify us (i.e. submit a 'notifiable alteration') as soon as possible, using the address VCA (Whole Vehicle), Room 1.2, The Eastgate Office Centre, Eastgate Road, Bristol BS5 6XX.

5. VCA is continually scrutinising the quality of the service it provides to customers, in order to discover more ways in which the standard can be improved. If you have a specific complaint concerning the way this job has been dealt with, our customer services leaflet gives guidance on the best approach. If you would like a copy, please contact the undersigned.

Yours sincerely

Product Certification



VCA Midlands Centre
Nuneaton, Warwickshire, UK
Switchboard: +44 (0)247 632 8421
Fax: +44 (0)247 632 9276
Email: enquiries@vca.gov.uk

VCA Millbrook Centre
Millbrook, Bedford, UK
Telephone: +44 (0)1525 408466
Email: millbrook@vca.gov.uk

VCA North America
Northville, Michigan, USA
Switchboard: +1 248 4680151
Main Fax: +1 248 3499261
Email: general@vcana.com
Web: www.vcana.com

Ohio office
Ashland, Ohio, USA
Telephone: +1 419 207 8123
Fax: +1 419 207 1193
Email: c.gepper@vcana.com
Web: www.vcana.com

VCA East Asia
Naka-ku, Nagoya, Japan
Telephone: +81 52 683 8831
Fax from Europe: +44 (0) 870 125 3704
Fax from East Asia: +81 (0) 6 7500 1280
Email: enquiries@vca-asia.jp
Web: www.vca-asia.net

VCA Malaysia
Selangor, Malaysia
Telephone: +6 037 494 0221
or +6 037 494 4868
Fax: +6 037 494 0225
Email: paultownend.vca@myjaring.net

VCA China
Beijing
Telephone: +8610 852 830 91/2/3
Fax: +8610 852 830 97



1. CONDITIONS

1.1 This Approval may be withdrawn at any time and while held is subject to the following conditions.

2. CONDITIONS OF MOTOR VEHICLE PARTS

2.1 The holder of this approval shall put the approval mark described in the Motor Vehicles (Designation of Approval Marks) Regulations 1979 as amended only on Motor Vehicle Parts that:

- a. Have been manufactured, assembled or completed in factories under his control and
- b. Conform in all material respects with the samples, which were tested before this approval was issued.

2.2 The holder of this approval shall mark his products in the manner set out in the relevant Regulation/Directive as given in the Motor Vehicles (Designation of Approval Marks) Regulations 1979 as amended together with:

- a. The approval number allocated by the Secretary of State for Transport.
- b. His name or trademark
- c. Any other markings specified in the appropriate international Regulation

2.3 The holder of this approval shall be prepared at any time to satisfy Department for Transport officials or agents of the Department, that the quality of the part being produced and marked or intended to be by him with the approval marking conforms in all material respects with that of the samples tested as the International Regulation requires.

2.4 The holder of this approval undertakes to admit duly authorised officials or agents of the Department at all reasonable times to any premises in which parts marked or intended to be marked are being manufactured, assembled or stored and to permit any such official or agent to inspect parts and all records relating to them and their production processes.

2.5 This approval may be suspended or withdrawn by the Secretary of State for Transport at any time without any particular length of notice being given and in the event of that being done the holder will absolve the Secretary of State from any claim for damages or compensation.

3. CONDITIONS FOR MOTOR VEHICLES

3.1 The holder of this approval shall put the approval mark described in the Motor Vehicles (Designation of Approval Marks) Regulation 1979 as amended only on Motor Vehicles fitted with Motor Vehicle parts which Motor Vehicles as fitted with such parts conform with the type of Motor Vehicle approved by as on behalf of the Secretary of State for Transport and only on Motor Vehicles that:

- a. Have been manufactured, assembled or completed in factories under his control and
- b. Conform in all material respects with the type of Motor Vehicle, which was tested before an approval certificate was issued.

3.2 The holder of this approval shall mark motor vehicles of the type approved. In the matter set out in the relevant Regulation/Directive using the authorised approval mark as given in the Motor Vehicles (Designation of Approval Marks) Regulation 1979 as amended together with the approval number allocated by the Secretary of State for Transport.

3.3 The holder of this approval shall mark Motor Vehicles of the type approved in the manner set out in the relevant Regulation annexed to the United Nations agreement of 1958 as amended using the authorised approval mark which comprises a capital letter E followed by the number 11 within a circle together with the approval number allocated by the Secretary of State for Transport.

3.4 The holder of this approval shall be prepared at any time to satisfy Department for Transport officials or agents of the Department that Motor Vehicles of the type approved which have been produced and marked or that are intended to be marked by him conform in all material respects with the type of vehicle approved.

3.5 The holder of this approval undertakes to admit duly authorised officials or agents of the Department at all reasonable times to any premises in which the Motor Vehicles of the type approved which have been or are intended to be marked are manufactured, assembled or stored and to permit any such official or agent to inspect the Motor Vehicles and all records relating to them and their production processes.

3.6 This approval may be suspended or withdrawn by the Secretary of State for Transport at any time without any particular length of notice given and in the event of that being done the holder will absolve the Secretary of State from any claim for damages or compensation.





VCA Headquarters
1 The Eastgate Office Centre
Eastgate Road
Bristol, BS5 6XX
United Kingdom

Switchboard: +44 (0) 117 951 5151
Main Fax: +44 (0) 117 952 4103
Email: enquiries@vca.gov.uk
Web: www.vca.gov.uk

THE UNITED KINGDOM VEHICLE APPROVAL AUTHORITY



COMMUNICATION CONCERNING THE APPROVAL GRANTED ⁽⁴⁾/~~APPROVAL EXTENDED ⁽⁴⁾/~~ APPROVAL REFUSED ⁽⁴⁾/~~APPROVAL WITHDRAWN ⁽⁴⁾/~~ PRODUCTION DEFINITELY DISCONTINUED ⁽⁴⁾ OF A TYPE OF DEVICE PURSUANT TO REGULATION NO. 7.02 SUPPLEMENT 17

Approval No: 07R - 025652

Extension No: Not applicable

1. Trade name or mark of the device: 
2. Manufacturer's name for the type of device: JS-11309(Grouped lamp)
3. Manufacturer's name and address: Dong Guan Jia Hong Auto Accessories Co., LTD., YangKengTang Village DaLang Town, DongGuan City, GuangDong Province, P.R.China
4. If applicable, name and address of the manufacturer's representative: Not applicable
5. Submitted for approval on: 12 April 2011
6. Technical service responsible for conducting approval tests: Vehicle Certification Agency
7. Date of report issued by that service: 12 April 2011
8. Number of report issued by that service: KSL218333(5652)
9. Concise description:
 - 9.1. By category of lamp: A for front position lamp
For mounting either outside ~~or inside or both~~: ⁽¹⁾
Colour of light emitted: ~~red~~/white ⁽¹⁾

KSL218333



Number, category and kind of light source(s): 1 LED, Non-replaceable light source

Voltage and wattage: 12V 0.3W / 24V 0.5W

Light source module specific identification code: Not applicable

Only for installation on M₁ and/or N₁ category vehicles: ~~yes~~/ no ⁽¹⁾

Only for limited mounting height of equal to or less than 750 mm above the ground:
~~yes~~/no ⁽¹⁾

Geometrical conditions of installation and relating variations, if any: Not applicable

Application of an electronic light source control gear/variable intensity control: Not applicable

(a) being part of the lamp: ~~yes~~/no ⁽¹⁾

(b) being not part of the lamp: ~~yes~~/no ⁽¹⁾

Input voltage(s) supplied by an electronic light source control gear/variable intensity control: Not applicable

Electronic light source control gear/variable intensity control manufacturer and identification number (when the light source control gear is part of the lamp but is not included into the lamp body): Not applicable

Variable luminous intensity: ~~yes~~/no ⁽¹⁾

9.2 Function(s) produced by an interdependent lamp forming part of an interdependent lamp system:

Front position lamp	yes / no ⁽¹⁾
R1 Rear position lamp	yes / no ⁽¹⁾
R2 Rear position lamp	yes / no ⁽¹⁾
S1 Stop lamp	yes / no ⁽¹⁾
S2 Stop lamp	yes / no ⁽¹⁾
S3 Stop lamp	yes / no ⁽¹⁾
S4 Stop lamp	yes / no ⁽¹⁾
End-outline marker lamp	yes / no ⁽¹⁾

10. Position of the approval mark: Marked on the lens

11. Reason(s) for extension (if applicable): Not applicable

12. Approval GRANTED/REFUSED/EXTENDED/WITHDRAWN: ⁽¹⁾

13. Place: BRISTOL

14. Date: 14 APRIL 2011

15. Signature:

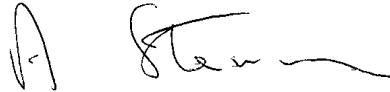

A. W. STENNING
Head of Technical and Quality Group

16. The list of documents deposited with the Administrative Service which has granted approval is annexed to this communication and may be obtained on request.

(1) Strike out what does not apply



VCA Headquarters
1 The Eastgate Office Centre
Eastgate Road
Bristol, BS5 6XX
United Kingdom

Switchboard: +44 (0) 117 951 5151
Main Fax: +44 (0) 117 952 4103
Email: enquiries@vca.gov.uk
Web: www.vca.gov.uk

THE UNITED KINGDOM VEHICLE APPROVAL AUTHORITY



COMMUNICATION CONCERNING THE APPROVAL GRANTED ⁽¹⁾/
~~APPROVAL EXTENDED ⁽⁴⁾/APPROVAL REFUSED ⁽⁴⁾/APPROVAL~~
~~WITHDRAWN ⁽⁴⁾/PRODUCTION DEFINITELY DISCONTINUED ⁽¹⁾~~ OF A
TYPE OF DAYTIME RUNNING LAMP PURSUANT TO REGULATION NO:
87

Approval No: 87R-005652

Extension No: Not applicable

1. Trade name or mark of the device: 
2. Manufacturer's name for the type of device: JS-11309(Grouped lamp)
3. Manufacturer's name and address: Dong Guan Jia Hong Auto Accessories Co., LTD.,
YangKengTang Village DaLang Town, DongGuan City, GuangDong Province, P.R.China
4. If applicable, name and address of the manufacturer's representative: Not applicable
5. Submitted for approval on: 12 April 2011
6. Technical service responsible for conducting approval tests: Vehicle Certification Agency
7. Date of test report issued by that service: 12 April 2011
8. Number of test report issued by that service: KSL218333(5652)
9. Concise description:
By category of lamp: RL for daytime running lamp
Number, category and kind of light source(s): ⁽²⁾ 1 LED, Non-replaceable light sources
Voltage and wattage: 12V 3W / 24V 4W



Application of an electronic light source control gear: Not applicable

- being part of the lamp yes/no ⁽¹⁾
- being not part of the lamp yes/no ⁽¹⁾

Input voltage supplied by an electronic light source control gear: Not applicable

Electronic light source control gear manufacturer and identification number (when the light source control gear is part of the lamp but is not included into the lamp body: Not applicable

10. Position of the approval mark: Marked on the lens

11. Reason(s) for extension (if applicable): Not applicable

12. Approval GRANTED/~~EXTENDED~~/~~REFUSED~~/~~WITHDRAWN~~ ⁽¹⁾

13. Place: BRISTOL

14. Date: 14 APRIL 2011

15. Signature:

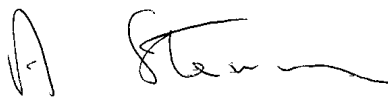

A. W. STENNING
Head of Technical and Quality Group

16. The following documents, bearing the approval number shown above, are available on request:

(1) Strike out what does not apply.

(2) For daytime running lamps with non-replaceable light sources indicate the number and total wattage of the light sources used.

First application date:

1. Specification data

Type		JS-11309(Grouped lamp)	
Function		Daytime Running Lamp	Front Position Lamp
Emitted colour		White	White
Rated	Voltage	12V /24V	
	Wattage	12V-3W / 24V-4W	12V-0.3W / 24V-0.5W
Applicable Regulation (ECE)		R87.00 RL	R7.02 Category A
Light Source		1 LED, Non-replaceable light source	1 LED, Non-replaceable light source
Location of marking	Light source	Rated Voltage and Wattage	
		12V-3W / 24V-4W	12V-0.3W / 24V-0.5W
	Marked on the back		
	Trade mark		
Approval mark	Marked on the lens		
		Marked on the lens	

2. Construction and material

Construction	Material	Remarks
Lens	Plastic (Thermoplastic resin)	
Housing	Metal(Aluminium)	
Reflector	Electroplated Silver (coating)	
Electrical wiring	Copper covered with insulation	

3. Name and address of manufacturer : Dong Guan Jia Hong Auto Accessories Co., LTD., YangKengTang Village DaLang Town, DongGuan City, Guangdong Province, P.R.China
4. Name and address of representative of manufacturer : Not applicable

This information document consists of 4 pages.



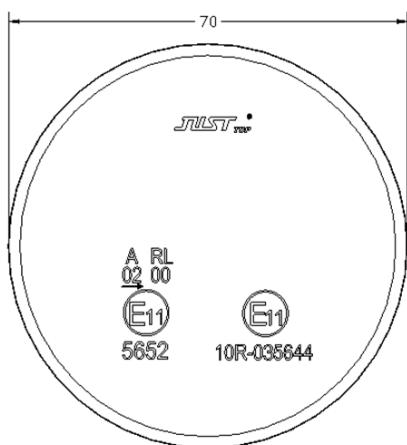
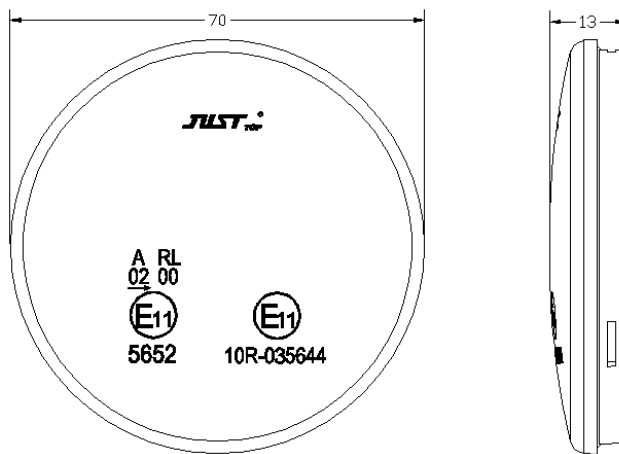
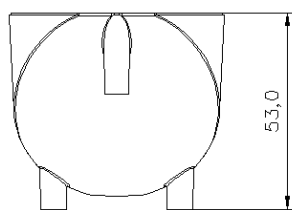
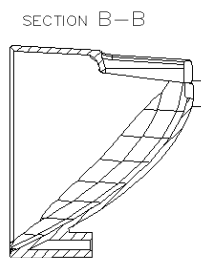
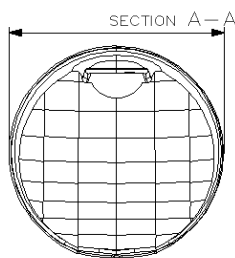
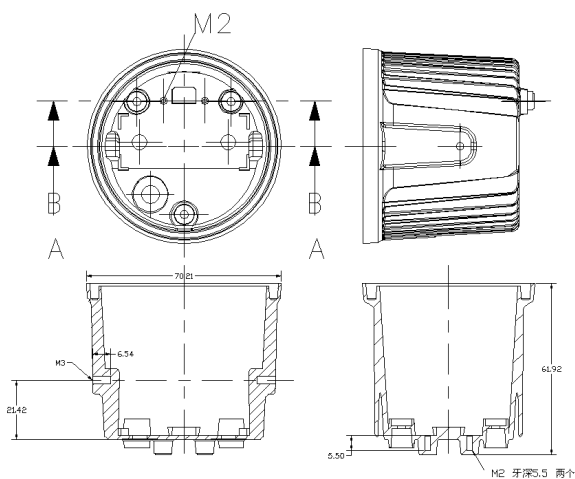

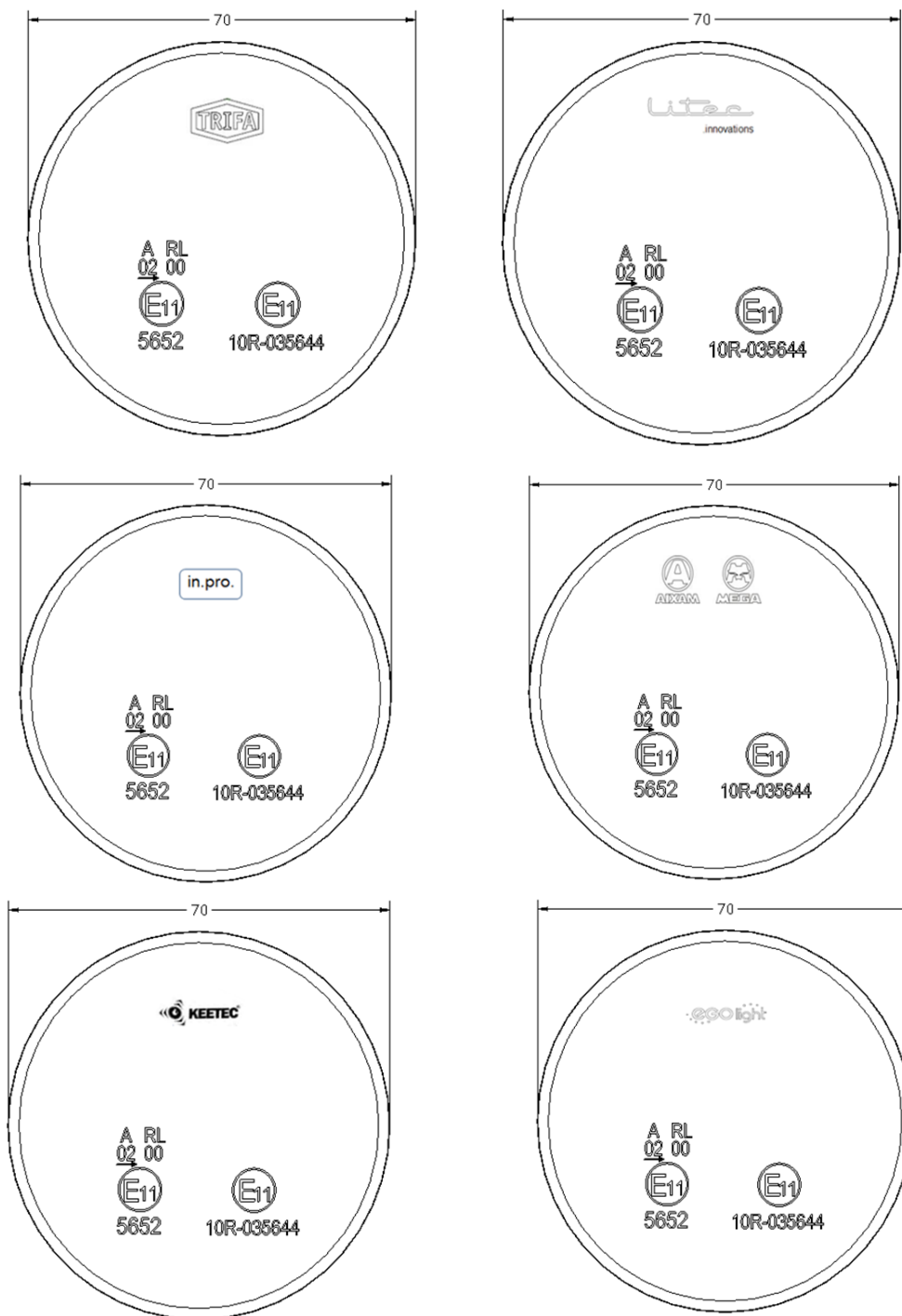

JS-11309原理

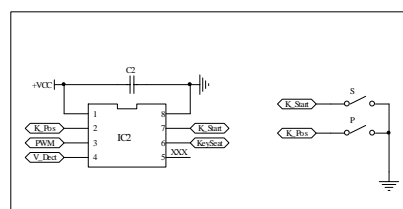
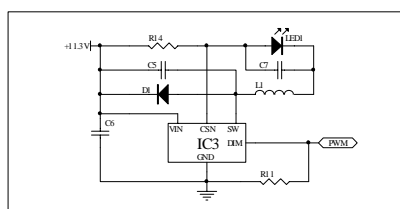
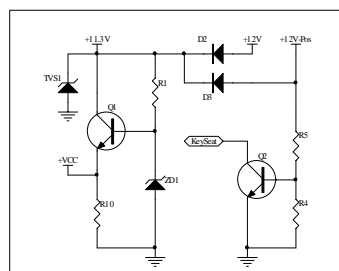
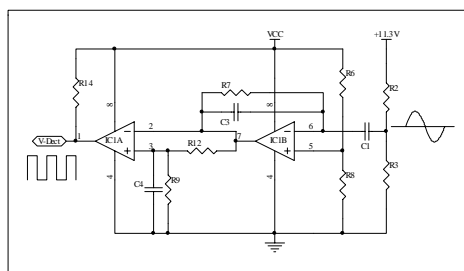





Vehicle Certification Agency,
1 The Eastgate Office
Centre
Eastgate Road,
Bristol,
BS5 6XX,
United Kingdom.
Telephone: +44 (0) 117 951 5151
Fax: +44 (0) 117 952 4103
Email: enquiries@vca.gov.uk
www.vca.gov.uk

TEST REPORT: Side(Position), Rear, Stop lamps
Regulation 7.02

REPORT/JOB NUMBER: KSL218333(5652)

TEST DETAILS

Location of Test	Vehicle Products Laboratory of Jiangsu University
Date of Test	12 April 2011
VCA Representative	Sung-Wook Yoon
Manufacturer's Representative	Mr. Wang
Reason for Test	New Approval

MANUFACTURER DETAILS

Manufacturer's Name	Dong Guan Jia Hong Auto Accessories Co., LTD.
Manufacturer's Address	YangKengTang Village DaLang Town, DongGuan City, GuangDong Province, P.R.China
Model Type & description	JS-11309(Grouped lamp)
Category	A for front position lamp

CONCLUSION

The above mentioned component was tested in accordance with ECE Regulation 7.02 Side(Position)/ Rear/ Stop lamps was found to comply in all respects

Signature:

Name: S.W. Yoon
Position: Type Approval Engineer
Date: 12 April 2011

LIST OF ANNEXES

ANNEX	No of PAGES	SUBJECT
1	1	E-mark photo
2	-	
3	-	
4	-	



**TEST REPORT: Side(Position), Rear,
Stop lamps**
Regulation 7.02

TEST SPECIFICATION AND WORST CASE RATIONALE

Grouped lamp with front position lamp and daytime running lamp. 12V and 24V can be used.
Test was done using 24V for worst case.

Tests required (if more than one is applicable)

- Required tests depend on R7.02

MANUFACTURER'S DOCUMENTATION

Manufacturer's documentation is complete and reflects the agreed specification for the component tested and covers all variants and versions agreed in the worse case rationale

Yes

FACILITY AND EQUIPMENT CHECKS

- | | | | | |
|---|---|----------------------------------|----------------------|-----|
| 1 | Generic Risk assessment followed | <i>Insert RA identifier here</i> | <input type="text"/> | N/A |
| | OR | | | |
| | Specific Risk assessment completed and stored in electronic job folder | | | N/A |
| 2 | Facilities and test equipment are appropriate | | | Yes |
| | Brief description of test equipment: See below table 3 | | | |
| 3 | Calibration certificates checked and valid, recorded in the following table | | | Yes |

Equipment	Make/Type/Serial No.	Validation date
Photometric / Colour test	OPTRONIK/SMS 10h/901025	2011.11.30.





Paragraph	Requirement	Complies (Yes,No,N/A)
6., Annex 1	<p>Category of side(position), rear, stop lamps and additional symbols</p> <p>Front position lamps(Letter A) Rear position lamps(Letter R) -the figure "1" when the device produces steady luminous intensity -the figure "2" when the device produces variable luminous intensity Front end-outline marker lamp(Letter AM) Rear end-outline marker lamp(Letter RM) -the figure "1" when the device produces steady luminous intensity -the figure "2" when the device produces variable luminous intensity Stop lamps(Letter S) "1" when the device produces steady luminous intensity "2" when the device produces variable luminous intensity "3" when the device meets the specific requirements for category S3 stop lamps and produces steady luminous intensity "4" when the device meets the specific requirements for category S4 stop lamps and produces variable luminous intensity On devices comprising both a rear position lamp and a stop lamp meeting the requirements of this Regulation in respect of such lamps, the letters "R" or "R1" or "R2" and "S1" or "S2" as the case may be, separated by a horizontal dash;</p>	
2.1.2	End-outline marker lamp is intended to emit white/ red* light	N/A
2.1.3	Front/rear position lamps intended to emit white/selective yellow/red* light	Complies
2.1.4, 2.2.5	In case of S3 stop lamp, it will be mounted inside / outside* of the vehicle	N/A
2.2.1	Geometrical mounting position is as vehicle specification, use test jig	Complies

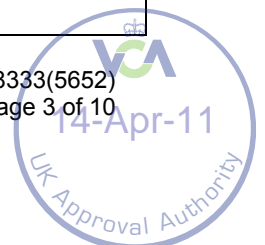



**TEST REPORT: Side(Position), Rear,
Stop lamps**
Regulation 7.02

Paragraph	Requirement	Complies (Yes,No,N/A)
	where applicable	Complies
VISUAL INSPECTION		
3.	Markings	
3.1	Trade name / trade mark* of maker marked clearly, legibly and indelibly	Complies
3.2	Category of filament lamps / light source module specific identification code* marked clearly, legibly and indelibly (N/A for non-replaceable light sources)	N/A
3.3	Drawings shows sufficient space for approval markings and additional symbols	Complies
3.4	In case of lamps with non-replaceable light sources or light source module, rated voltage and rated wattage	Complies
3.5	If rated voltage is other than 6V, 12V, 24V then secondary design voltage is marked	N/A
3.6	Light source module	
3.6.1	Trade name / trade mark* of maker marked clearly, legibly and indelibly	N/A
3.6.2	Identification code of the module start with "MD" followed by the approval numbers without the E in a circle marked clearly, legibly and indelibly	N/A
3.6.3	Rated voltage and rated wattage marked	N/A





**TEST REPORT: Side(Position), Rear,
Stop lamps**
Regulation 7.02

<i>Paragraph</i>	<i>Requirement</i>	<i>Complies (Yes,No,N/A)</i>
4.2.2.5	Position lamps with visibility angles asymmetrical about the reference axis, marked with horizontal arrow towards the outside	Complies
4.2.2.6	Lamps may be used as assembly of two lamps marked with "D"	N/A
4.2.2.7	For lamps with reduced light distribution marking with vertical arrow directed downward (installed less than 750mm from ground, verified up to an angle of 5 degrees downward)	N/A
4.2.4	Approval mark and symbols of lamp clearly legible and indelible even when mounted on the vehicle (acceptable if concealed only by hood or trunk)	Complies
4.3.2.1	Grouped/ combined/reciprocally incorporated / non-replaceable light sources lamps comply with all relevant regulations, may have a single approval mark	Complies
4.3.2.1.2	No part of the Grouped/ combined/reciprocally incorporated / non-replaceable light sources lamps can be removed without at the same time removing the approval mark	Complies
4.3.2.2.2	Grouped/ combined/reciprocally incorporated / non-replaceable light sources lamps identification symbols for each functions are clearly identified	Complies
5.	GENERAL SPECIFICATIONS	
	Grouped/ combined/reciprocally incorporated / non-replaceable light sources lamps, all functions meet relevant regulations	Complies
5.2	Lamps designed and constructed to ensure that their performance	

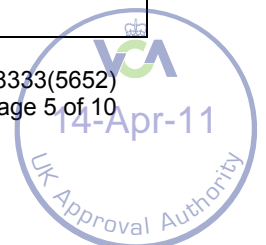



**TEST REPORT: Side(Position), Rear,
Stop lamps**
Regulation 7.02

Paragraph	Requirement	Complies (Yes,No,N/A)
	under normal conditions of use of this regulation notwithstanding vibrations, will meet the requirements	Complies
5.5.5	Rear(side) position lamps reciprocally incorporated with a stop lamp shall be either: Part of a multiple light source arrangement OR incorporate a failure monitoring system for that function:	N/A N/A
5.6.1	Light source module can be fitted only with original parts and in the correct position	N/A
5.6.2	Light source module is tamperproof	N/A
6.1	Single lamp contains more than one light source, having the same function: Test with one light source failed (Light source arrays connected in series are considered a single lamp)	Complies N/A
6.2.4.1	Minimum intensity complies throughout the fields defined in annex 1	Complies
6.2.4.2	For reciprocally incorporated rear position and stop lamps, ratio of light intensity with rear position only/both filaments lit exceeds 5:1 at the light distribution table pass through $\pm 5^\circ V$ and $\pm 10^\circ H$ field. (for dual intensity stop lamps, check at 'night' condition only)	N/A
6.4	For dual intensity stop lamps, switching time for 'night time' condition to reach 90% of measured intensity does not exceed that of the 'daytime' condition	N/A
7.1	All measurement made with colourless standard filament lamps	N/A
7.1.2	OR non-replaceable light source module with 6.75V 13.5V/28.0V*	Complies





**TEST REPORT: Side(Position), Rear,
Stop lamps
Regulation 7.02**

Paragraph	Requirement	Complies (Yes,No,N/A)
7.1.3	OR special power supply requested by manufacturer	N/A
7.2-7.3	Others:	N/A
7.4	Limits of apparent surface in the direction of the reference axis defined	Complies
7.6	In case of category S3 stop lamps mounted inside of vehicle, the position is as specified in the drawing and tests conducted through sample window plate(s)	N/A
Annex 4	Trichromatic co-ordinates of white light are within limits: $0.310 \leq x \leq 0.500$, $y \leq 0.150 + 0.640x$, $y \geq 0.050 + 0.750x$, $0.382 \leq y \leq 0.440$ 1) $x= 0.3121$, $y= 0.3253$ 2) $x=0.3151$, $y= 0.3307$	Complies
Annex 3, 4.3	The luminous intensities measured after one minute and after 30 minutes of operation shall comply with the minimum and maximum requirements	

	HV		Ratio	
	After 1 minutes	After 30 minutes		
Sample No 1	68.49	67.84	1.010	
	Maximum value at 1 minute : $1.010 \times 69.137 = 69.828$			Complies
Sample No 2	69.93	68.30	1.024	
	Maximum value at 1 minute : $1.024 \times 68.30 = 69.939$			Complies

Table of photometric requirements

Category	Minimum intensities cd		Maximum values cd when used as	
			single lamp	Lamp (single) marked "D"
	HV	Defined field		
Front position lamps/ front end-outline marker lamp	4	0.05	140	70





**TEST REPORT: Side(Position), Rear,
Stop lamps**
Regulation 7.02

Paragraph	Requirement	Complies (Yes,No,N/A)
-----------	-------------	--------------------------

A or AM				
Front position lamps incorporated in headlamp	4	0.05	140	-
Rear position lamps, rear end-outline marker lamp R, R1 or RM1(steady)	4	0.05	17 ¹⁾	8.5
R2 or RM2(variable)	4		42	21
Stop lamps S1(Steady)	60	0.3	260	130
S2(Variable)	60	0.3	730	365
S3(Steady)	25	0.3	110	55
S4(Variable)	25	0.3	160	80

1) Reciprocally incorporated with stop lamps max 60cd shall be permitted below 5° below horizontal plane





**TEST REPORT: Side(Position), Rear,
Stop lamps
Regulation 7.02**

Paragraph	Requirement	Complies (Yes,No,N/A)
-----------	-------------	--------------------------

TEST RESULTS

Photometry:

Test voltage(V):			27.991	27.992	
Test current(A):			0.02	0.02	
Point	Min	Max	Sample #1	Sample #2	Remark
10U-5L	0.80	140.00	3.836	6.081	
10U-5R	0.80	140.00	5.569	5.415	
5U-20R	0.40	140.00	9.586	4.995	
5U-10R	0.80	140.00	33.29	26.04	
5U-V	2.80	140.00	34.53	37.49	
5U-10L	0.80	140.00	21.79	32.83	
5U-20L	0.40	140.00	8.456	17.55	
H-10L	1.40	140.00	53.73	62.47	
H-5L	3.60	140.00	67.64	66.91	
H - V	4.00	140.00	67.84	68.30	
H-5R	3.60	140.00	65.45	62.11	
H-10R	1.40	140.00	54.07	46.47	
5D-20R	0.40	140.00	7.904	5.191	
5D-10R	0.80	140.00	34.55	34.62	
5D-V	2.80	140.00	48.75	49.18	
5D-10L	0.80	140.00	44.3	45.28	
5D-20L	0.40	140.00	18.62	25.37	
10D-5L	0.80	140.00	17.97	17.54	
10D-5R	0.80	140.00	11.7	19.46	
Defined field min ~ max	0.05	140.00	0.066 ~69.137	0.061~68.018	





**TEST REPORT: Side(Position), Rear,
Stop lamps**
Regulation 7.02

<i>Paragraph</i>	<i>Requirement</i>	<i>Complies (Yes,No,N/A)</i>
------------------	--------------------	----------------------------------

Boundaries of apparent surface:

Boundary	Distance from H=V=0°
Up	28.5 mm
Down	28.5 mm
Left	28.5 mm
Right	28.5 mm





**TEST REPORT: Side(Position), Rear,
Stop lamps**
Regulation 7.02

Annex 1 – E-mark photo





Vehicle Certification Agency,
1 The Eastgate Office Centre
Eastgate Road,
Bristol,
BS5 6XX,
United Kingdom.
Telephone: +44 (0) 117 951 5151
Fax: +44 (0) 117 952 4103
Email: enquiries@vca.gov.uk
www.vca.gov.uk

TEST REPORT: Daytime Running Lamps
Regulation 87.00 (Revision 2 Amend 3)

REPORT/JOB NUMBER: KSL218333(5652)

TEST DETAILS

Location of Test	Vehicle Products Laboratory of Jiangsu University
Date of Test	12 April 2011
VCA Representative	Sung-Wook Yoon
Manufacturer's Representative	Mr. Wang
Reason for Test	New Approval

MANUFACTURER DETAILS

Manufacturer's Name	Dong Guan Jia Hong Auto Accessories Co., LTD.
Manufacturer's Address	YangKengTang Village DaLang Town, DongGuan City, GuangDong Province, P.R.China
Model Type & description	JS-11309(Grouped lamp)
Category	RL for daytime running lamp

CONCLUSION

The above mentioned component was tested in accordance with ECE Regulation 87.00 Daytime Running Lamps was found to comply in all respects

Signature:

Name: S.W. Yoon
Position: Type Approval Engineer
Date: 12 April 2011

LIST OF ANNEXES

ANNEX	No of PAGES	SUBJECT
1	1	E-mark photo
2	-	-
3	-	-
4	-	-



TEST REPORT: Daytime Running Lamps
Regulation 87.00

TEST SPECIFICATION AND WORST CASE RATIONALE

Grouped lamp with front position lamp and daytime running lamp. 12V and 24V can be used.
Test was done using 24V for worst case.

Tests required (if more than one is applicable)

- Required tests depend on R87.00

MANUFACTURER'S DOCUMENTATION

Manufacturer's documentation is complete and reflects the agreed specification for the component tested and covers all variants and versions agreed in the worse case rationale

Yes

FACILITY AND EQUIPMENT CHECKS

- | | | |
|---|---|-----|
| 1 | Generic Risk assessment followed <i>Insert RA identifier here</i> <input type="text"/> | N/A |
| | OR
Specific Risk assessment completed and stored in electronic job folder | N/A |
| 2 | Facilities and test equipment are appropriate
Brief description of test equipment: See below table 3 | Yes |
| 3 | Calibration certificates checked and valid, recorded in the following table | Yes |

Equipment	Make/Type/Serial No.	Validation date
Photometric / Colour test	OPTRONIK/SMS 10h/901025	2011.11.30.





**TEST REPORT: Daytime Running
Lamps
Regulation 87.00**

Paragraph	Requirement	Complies (Yes, No, N/A)
VISUAL INSPECTION		
4. Markings		
4.1	Trade name / trade mark* of maker marked clearly, legibly and indelibly	Complies
4.2	Category of filament lamps / light source module specific identification code* marked clearly, legibly and indelibly (N/A for non-replaceable light sources)	N/A
	Drawings shows sufficient space for approval markings and additional symbols	Complies
4.3	In case of lamps with non-replaceable light sources or light source module, rated voltage and rated wattage	Complies
4.5	Light source module	
4.5.1	Trade name / trade mark* of maker marked clearly, legibly and indelibly	N/A
4.5.2	Identification code of the module starts with "MD" followed by the approval marking without the circle. This marking must be clear and indelible	N/A
4.5.3	Rated voltage and rated wattage marked	N/A
4.6.	Lamps operating at voltages other than the nominal rated voltages of 6- V , 12 V or 24 V respectively, by the application of an electronic light source control gear being not part of the lamp, must also bear a marking denoting the rated secondary design voltage.	Complies
4.7.	An electronic light source control gear being part of the lamp but not included into the lamp body shall bear the name of the manufacturer and its identification number[R87s8-14].	N/A
5.	COMPOSITION OF THE APPROVAL MARK	
	The approval mark shall consist of:	
5.2.1	an international approval marking, comprising:	Complies
5.2.1.1.	a circle surrounding the letter "E" followed by the distinguishing number of the country which has granted the approval 2/, [R87s9-15]	Complies
5.2.1.2.	an approval number	Complies





**TEST REPORT: Daytime Running Lamps
Regulation 87.00**

Paragraph	Requirement	Complies (Yes, No, N/A)
5.2.2.	the additional symbol "RL".	Complies
5.2.3.	The two digits of the approval number which indicate the series of amendments in force at the time of issue of the approval, may be marked close to the above additional symbols.	Complies
5.3 5.3.1	ARRANGEMENT OF THE APPROVAL MARK Independent lamps Annex 2, figure 1, to this Regulation gives an example of arrangement of the approval mark with the above-mentioned additional symbols	N/A
5.3.2	Grouped/combined/reciprocally incorporated/ non-replaceable light sources lamps	Complies
5.3.3.	Lamps reciprocally incorporated with other lamps, of which the lens may also be used for other types of devices The provisions laid down in paragraph 5.3.2. above are applicable.	N/A
6.	GENERAL SPECIFICATIONS	
6.2.	Daytime running lamps shall be so designed and constructed that in normal use, despite the vibration to which they may then be subjected, they continue to function satisfactorily and retain the characteristics prescribed by this Regulation	Complies
6.3.	Light source module	N/A
6.3.1.	The design of the light source module(s) shall be such that even in darkness the light source module(s) can be fitted in no other position, but the correct one.	N/A
6.3.2.	The light source module(s) shall be tamperproof[R1A1-16].	N/A
6.4	Daytime running lamps, which are reciprocally incorporated with another function, using a common light source, and designed to operate permanently with an electronic light source control gear to regulate the intensity of the light emitted, are permitted[R87s8-17].	N/A
7.	INTENSITY OF LIGHT	
7.1	The luminous intensity of the light emitted by each lamp shall not be less than 400 cd in the axis of reference.	Complies
7.2.	Outside the reference axis and within the angular fields defined in the arrangement diagram in Annex 7 to this Regulation, the intensity of the	





TEST REPORT: Daytime Running Lamps Regulation 87.00

Paragraph	Requirement	Complies (Yes, No, N/A)
-----------	-------------	----------------------------

light emitted by each lamp must:

Complies

7.2.1 In each direction corresponding to the points in the table of standard light distribution reproduced in Annex 3 to this Regulation, be not less than the minimum specified in paragraph 7.1.above, multiplied by the percentage specified in the said table of the direction in question, and

Complies

7.2.2. not exceed 1,200 cd in any direction the lamp is visible.

Complies

7.3 Moreover, throughout the field defined in the diagram in Annex 7, the intensity of the light emitted must not be less than 1.0 cd.[R87s10-18]

Complies

8. **APPARENT SURFACE**

The area of the apparent surface in the direction of the axis of reference of the lamp shall be not less than 25 cm² and not more than 200 cm².
[R87s10-20] : **25.5cm²**

Complies

10. **TEST PROCEDURE**

10.2 In the case of a system that uses an electronic light source control gear being part of the lamp 3/, all measurements, photometric and colorimetric, shall be made applying at the input terminals of the lamp a voltage of 6.75 V, 13.5 V or 28.0 V respectively[R87s9-22].

N/A

Annex 4 Trichromatic co-ordinates of white light are within limits:
 $0.310 \leq x \leq 0.500$, $y \leq 0.150 + 0.640x$,
 $y \geq 0.050 + 0.750x$, $0.382 \leq y \leq 0.440$
 1) $x=0.3121$, $y=0.3253$
 2) $x=0.3151$, $y=0.3307$

Complies

Annex 3, 4.3 The luminous intensities measured after one minute and after 30 minutes of operation shall comply with the minimum and maximum requirements

	HV		Ratio	
	After 1 minutes	After 30 minutes		
Sample No 1	603.5	561.50	1.075	
	Maximum value at 1 minute : $638.360 * 1.075 = 686.237$			Complies
Sample No 2	592.3	588.5	1.007	
	Maximum value at 1 minute : $606.750 * 1.007 = 610.997$			Complies

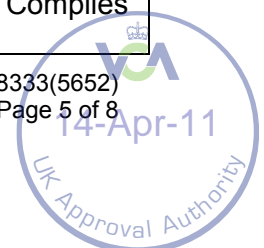



**TEST REPORT: Daytime Running
Lamps
Regulation 87.00**

<i>Paragraph</i>	<i>Requirement</i>	<i>Complies (Yes, No, N/A)</i>
------------------	--------------------	------------------------------------

11. HEAT RESISTANCE TEST

11.1	The lamp must be subjected to a one-hour test of continuous operation following a warm-up period of 20 minutes. The ambient temperature shall be 23°C+ 5°. The filament lamp used shall be a filament lamp of the category specified for the lamp, and shall be supplied with a current at a voltage such that it gives the specified average power at the corresponding test voltage. However, for lamps equipped with non-replaceable light sources (filament lamps and other), the test shall be made with the light sources present in the lamp, in accordance with paragraph 10.2. of this Regulation.	Complies
------	---	-----------------

11.2.	Where only the maximum power is specified, the test shall be carried out by regulating the voltage to obtain a power equal to 90% of the specified power. The specified average or maximum power referred to above shall in all cases be chosen from the voltage range of 6, 12 or 24 V at which it reaches the highest value; for lamps equipped with non-replaceable light sources (filament lamps and other) the test conditions set in paragraph 10.2. of this Regulation shall be applied.	N/A
-------	---	------------

11.3	After the lamp has been stabilized at the ambient temperature, no distortion, deformation, cracking or colour modification shall be perceptible. In case of doubt the intensity of light according to paragraph 7. above shall be measured. At that measurement the values shall reach at least 90% of the values obtained before the heat resistance test on the same device.	Complies
------	--	-----------------





**TEST REPORT: Daytime Running
Lamps
Regulation 87.00**

Paragraph	Requirement	Complies (Yes, No, N/A)
-----------	-------------	----------------------------

TEST RESULTS

Photometry:

Test voltage(V):			27.992	27.990
Test current(A):			0.127	0.107
Point	Min	Max	Sample #1	Sample #2
10U-5L	80	1200	96.47	88.13
10U-V	80	1200	123.00	92.93
10U-5R	80	1200	157.20	89.80
5U-20R	40	1200	239.50	89.76
5U-10R	80	1200	542.30	363.8
5U-V	280	1200	557.10	492.9
5U-10L	80	1200	328.40	374.6
5U-20L	40	1200	85.19	139.2
H-20L	100	1200	109.9	189.0
H-10L	280	1200	429.90	491.1
H-5L	360	1200	496.70	578.9
H-V	400	1200	561.50	588.5
H-5R	360	1200	552.50	590.3
H-10R	280	1200	488.30	457.9
H-20R	100	1200	199.60	105.0
5D-20R	40	1200	65.81	71.3
5D-10R	80	1200	260.60	284.0
5D-V	280	1200	290.10	384.5
5D-10L	80	1200	247.60	348.2
5D-20L	40	1200	53.35	105.9
Min-Max	1	1200	16.976~638.360	27.390~606.750





**TEST REPORT: Daytime Running
Lamps
Regulation 87.00**

<i>Paragraph</i>	<i>Requirement</i>	<i>Complies (Yes, No, N/A)</i>
------------------	--------------------	------------------------------------

Boundaries of apparent surface:

Boundary	Distance from H=V=0°
Up	28.5 mm
Down	28.5 mm
Left	28.5 mm
Right	28.5 mm





**TEST REPORT: Daytime Running
Lamps
Regulation 87.00**

Annex 1 – E-mark photo

