



INSTALLATION INSTRUCTIONS FOR PART 99-6507

APPLICATIONS

See application list inside

Dodge/Chrysler/Jeep/Mitsubishi multi-kit 2005-up 99-6507

KIT FEATURES

- DIN radio provision with pocket
- ISO DIN radio provision with pocket



KIT COMPONENTS

- A) Radio housing • B) ISO snap-in brackets • C) Trim plates (upper and lower)

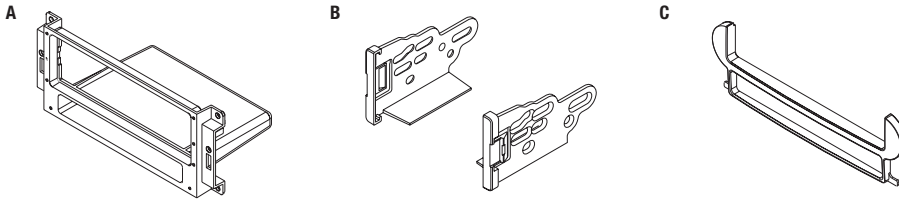

WIRING & ANTENNA CONNECTIONS (sold separately)

Wiring Harness:

- CHT0-01 - Chrysler amp interface harness 2004-up
- XSVI-6502-NAV - Chrysler RAP harness 2004-up

Antenna Adapter:

- 40-CR10 - Chrysler antenna adapter 2002-up

TOOLS REQUIRED

- Panel removal tool • Phillips screwdriver
- Socket wrench • Small flat blade screwdriver

CAUTION: Metra recommends disconnecting the negative battery terminal before beginning any installation. All accessories, switches, and especially air bag indicator lights must be plugged in before reconnecting the battery or cycling the ignition.

NOTE: Refer to the instructions included with the aftermarket radio.



99-6507

Applications

Chrysler

300	2005-2007
Aspen	2007
PT Cruiser	2006-2010

Dodge

Charger	2005-2007
Caliber	2007-2008
Dakota	2005-2007
Durango	2004-2007
Magnum	2005-2007

Ram 2006-2008 (*full center console*)

2500/3500 2009
2500/3500 chassis cab 2010

Ram 2006-2008 (*mini center console*)

2500/3500 2009
2500/3500 chassis cab 2010

Dodge (*continued*)

Ram 2006-2008 (<i>without center console</i>)
2500/3500 2009
2500/3500 chassis cab 2010

Jeep

Commander	2006-2007
Compass	2007-2008
Grand Cherokee	2005-2007
Patriot	2007-2008

Mitsubishi

Raider	2006-2007
--------------	-----------

Table of Contents

Dash Disassembly

- Chrysler 300 2005-2007	4
- Chrysler Aspen 2007	3
- Chrysler PT Cruiser 2006-2010	8
- Dodge Charger 2005-2007	3
- Dodge Caliber 2007-2008	7
- Dodge Dakota 2005-2007	3
- Dodge Durango 2004-2007	3
- Dodge Magnum 2005-2007	3
- Dodge Ram 2006-2008 (<i>full center console</i>), 2500/3500 2009, 2500/3500 chassis cab 2010	6
- Dodge Ram 2006-2008 (<i>mini center console</i>), 2500/3500 2009, 2500/3500 chassis cab 2010	5
- Dodge Ram 2006-2008 (<i>without center console</i>), 2500/3500 2009, 2500/3500 chassis cab 2010	4
- Jeep Commander 2006-2007	8
- Jeep Compass 2007-2008	7
- Jeep Grand Cherokee 2005-2007	7
- Jeep Patriot 2007-2008	7
- Mitsubishi Raider 2006-2007	9

Kit Assembly

- DIN radio provision with pocket	10
- ISO radio provision with pocket	11



Dash Disassembly 99-6507

Chrysler Aspen 2007, Dodge Dakota 2005-2007/Durango 2004-2007

1. Remove (2) 7mm screws from the inside of the pocket facing upward. (Figure A)
2. Unclip and remove the entire trim panel surrounding the radio and climate controls. (Figure B)
3. Remove (4) 7mm screws securing radio. Unplug and remove radio. (Figure C)

Continue to kit assembly

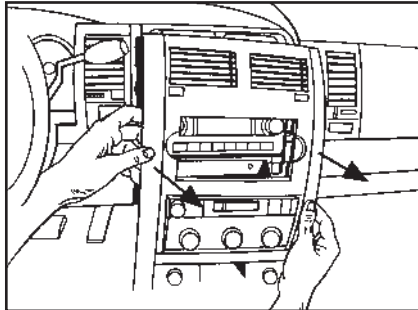

(Figure B)

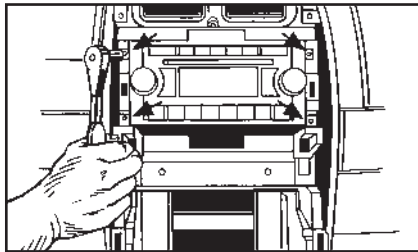

(Figure C)

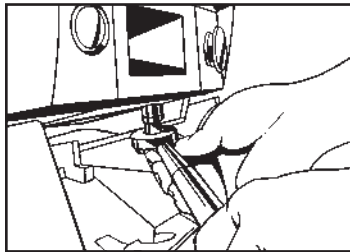

(Figure A)

Dodge Charger/Magnum 2005-2007

1. Unclip and remove entire panel surrounding radio and climate controls, including A/C vents. (Figure A)
2. Remove (4) 7mm screws securing radio. Unplug and remove radio. (Figure B)

Continue to kit assembly

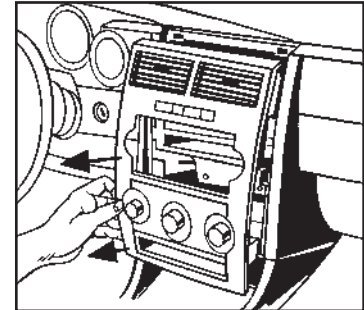

(Figure A)

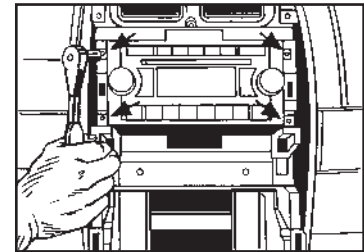

(Figure B)



Dash Disassembly 99-6507

Chrysler 300 2005-2007

1. Unclip and remove entire panel surrounding radio and climate controls, including A/C vents and clock. (Figure A)
2. Remove (4) 7mm screws securing radio. Unplug and remove radio. (Figure B)

Continue to kit assembly

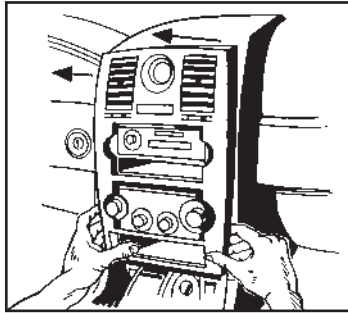

(Figure A)

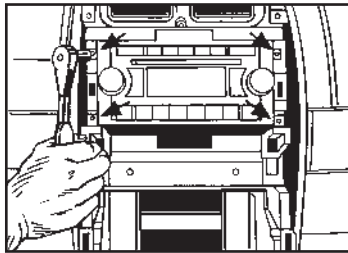

(Figure B)

Dodge Ram 2006-2008, 2500/3500 2009, 2500/2300 chassis cab 2010 (without center console)

1. Open cup holder and remove (2) Phillips screws facing up on front edge of radio/climate control panel. (Figure A)
2. Unclip and remove entire panel surrounding radio and climate controls, including A/C vents. (Figure B)
3. Remove (4) 7mm screws securing radio. Unplug and remove radio.

Continue to kit assembly

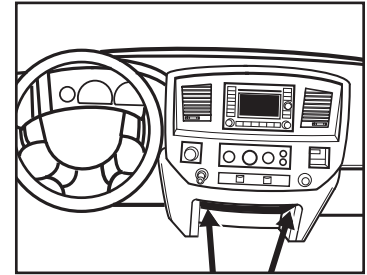

(Figure A)

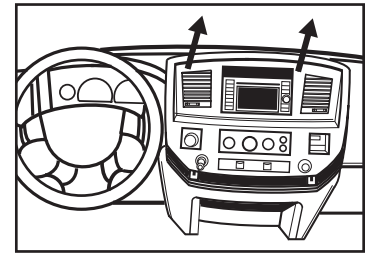

(Figure B)



Dash Disassembly 99-6507

Dodge Ram 2006-2008, 2500/3500 2009, 2500/2300 chassis cab 2010 (with mini center console)

1. If vehicle has floor shifter, remove shifter knob. Then remove center console inserts, if present. (Figure A)
2. Remove screws securing the rear center console to the floor panel. Lift up on the rear center console to clear the gear shift lever, if present. (Figure B)
3. Remove screws securing the front center console to the floor panel. Unclip and remove the front center console. (Figure C)
4. Remove (2) Phillips head screws at bottom of dash. Unsnap and remove lower panel. (Figure D)
5. Remove (2) Phillips screws facing up on front edge of radio/climate control panel. (Figure D)
6. Unclip and remove entire panel surrounding radio and climate controls, including A/C vents. (Figure E)
7. Remove (4) 7mm screws securing radio to dash and remove radio. (Figure E)

Continue to kit assembly

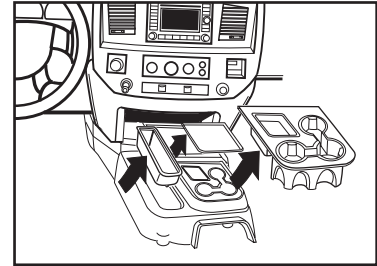

(Figure A)

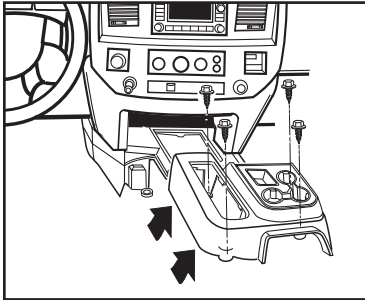

(Figure B)

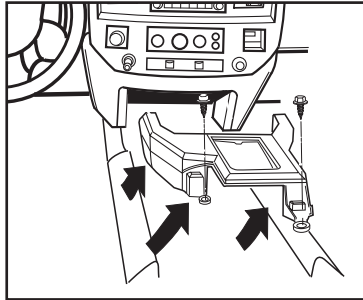

(Figure C)

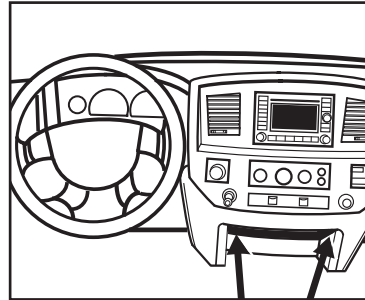

(Figure D)

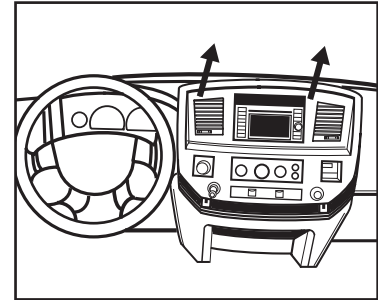

(Figure E)



Dash Disassembly 99-6507

Dodge Ram 2006-2008, 2500/3500 2009, 2500/2300 chassis cab 2010 (with full center console)

1. If vehicle has floor shifter, remove shifter knob.
 2. Unsnap and remove console front top cover (closest to the dash). (Figure A)
 3. Remove (2) 8mm screws from under console cover (previously removed). Remove front section of console. (Figure B)
 4. Loosen (2) 8mm screws at bottom of dash. Unsnap lower panel.
 5. Remove (2) Phillips screws facing up on front edge of radio/climate control panel. (Figure C)
 6. Unclip and remove entire panel surrounding radio and climate controls, including A/C vents. (Figure D)
 7. Remove (4) 7mm screws securing radio to dash and remove radio.
- Continue to kit assembly*

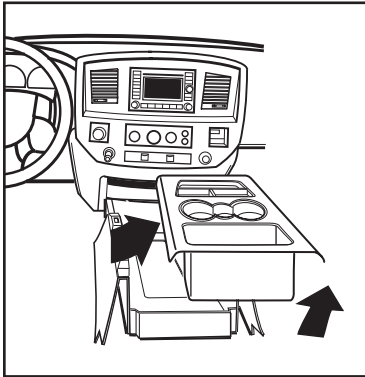

(Figure A)

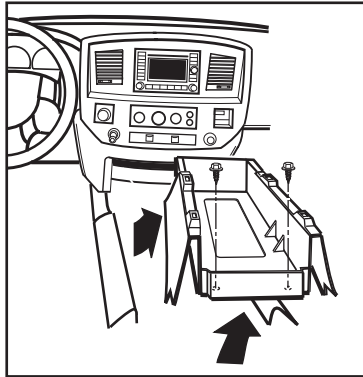

(Figure B)

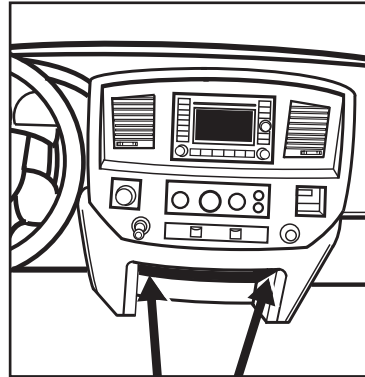

(Figure C)

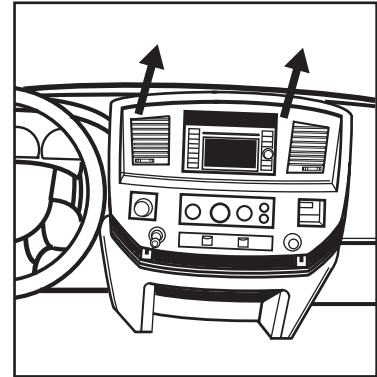

(Figure D)



Dash Disassembly 99-6507

Dodge Caliber 2007-2008, Jeep Compass/Patriot 2007-2008

1. Unsnap and move shifter trim to the side. (Figure A)
2. (Compass and Patriot only) Unsnap and remove top center dash panel above A/C vents.
3. Unsnap center dash trim panel (do not remove until climate controls are removed). (Figure A)
4. Remove (4) Phillips screws holding climate control panel to backside of the center dash panel.
5. Remove (4) 7mm screws securing radio. Unplug and remove radio.

Continue to kit assembly

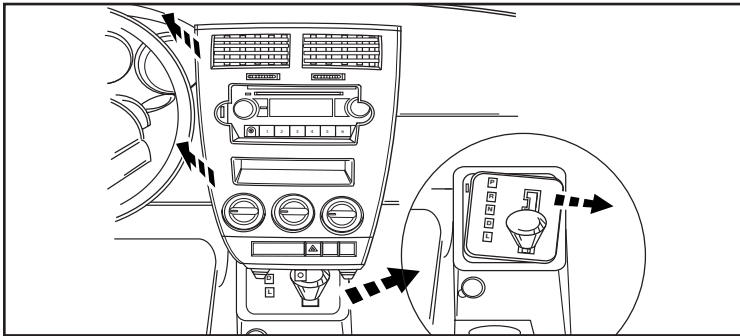

(Figure A)

Jeep Grand Cherokee 2005-2007

1. Unsnap and remove panel from around radio including the vent on each side. (Figure A)
2. Remove (4) 7mm screws securing radio. Unplug and remove radio. (Figure B)

Continue to kit assembly

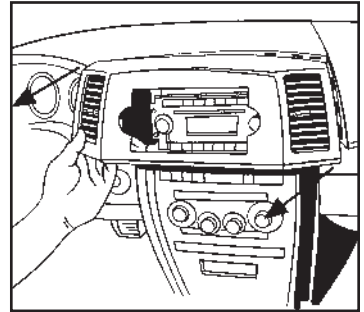

(Figure A)

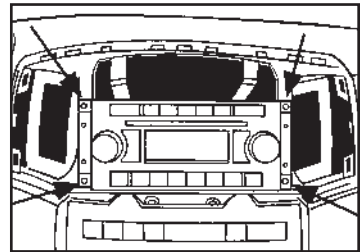

(Figure B)



Dash Disassembly 99-6507

Jeep Commander 2006-2007

1. Remove the (16) screws securing the radio trim panel. (Figure A)
2. Unclip and remove the entire radio trim panel. (Figure B)
3. Remove (4) 7mm screws securing radio. Unplug and remove radio.

Continue to kit assembly

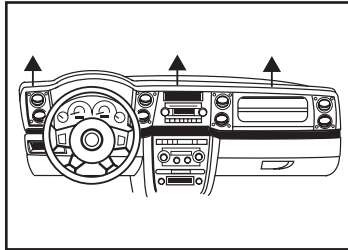

(Figure B)

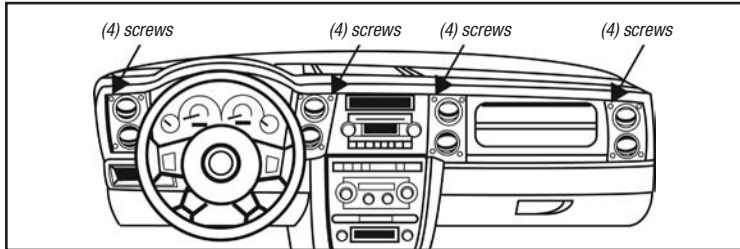

(Figure A)

Chrysler PT Cruiser 2006-2010

1. Remove (2) screws from inside air vents on center dash panel. (Figure A)
2. Unsnap center dash panel (do not remove until climate controls are removed). (Figure A)
3. Remove (4) Phillips screws holding climate control panel to backside of the center dash panel.
4. Remove (4) 7mm screws securing radio. Unplug and remove radio.

Continue to kit assembly

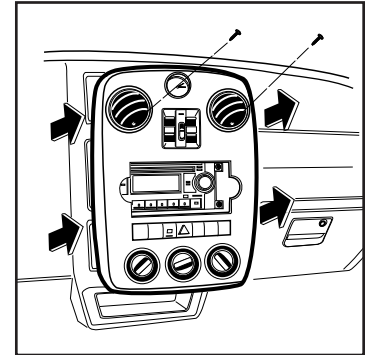

(Figure A)

Mitsubishi Raider 2006-2007

Notes

1. Unsnap and remove center dash panel. (Figure A)
2. Remove (4) 7mm screws securing radio. Unplug and remove radio.

Continue to kit assembly

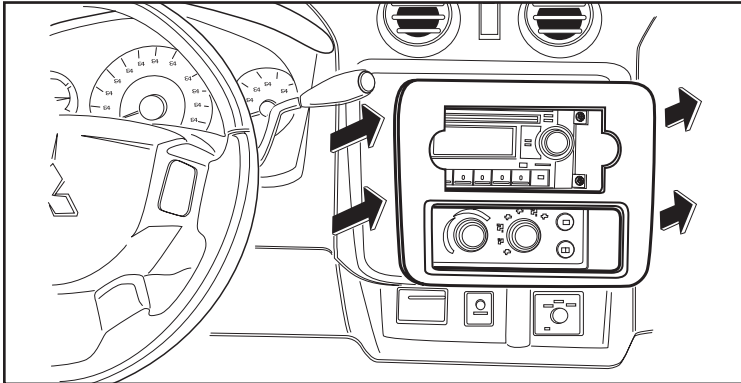

(Figure A)



Kit Assembly 99-6507

DIN radio provision with pocket

1. Slide the DIN cage into the Radio Housing and secure by bending the metal locking tabs down. (Figure A)

Note: You will need to remove the aftermarket radio's trim ring if equipped.

2. Slide the after-market head unit into the cage and secure. (Figure B)
3. Using the alignment pins on the trim plates & the corresponding holes in the housing, attach the upper trim plate and the lower trim plate supplied with the kit. (Figure B)

4. Locate the factory wiring harness in the dash. Metra recommends using the proper mating adapter from Metra or AXCESS. Re-connect the negative battery terminal and test the unit for proper operation.
5. Reassemble dash in reverse order of disassembly.

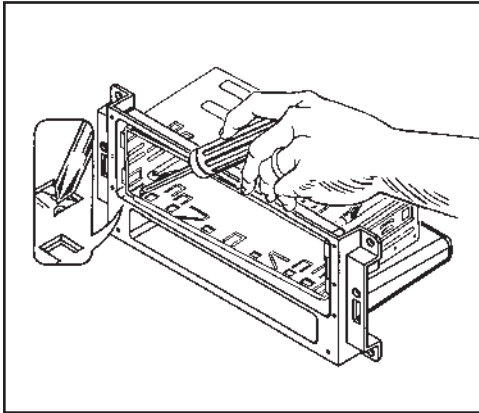

(Figure A)

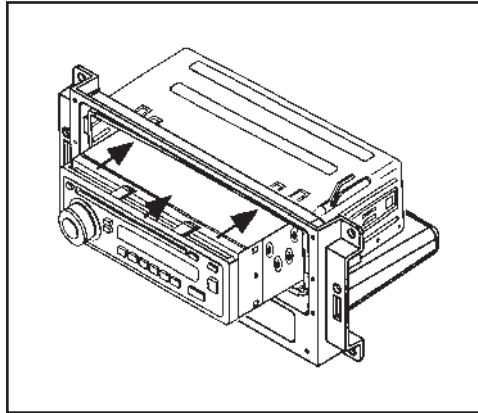

(Figure B)

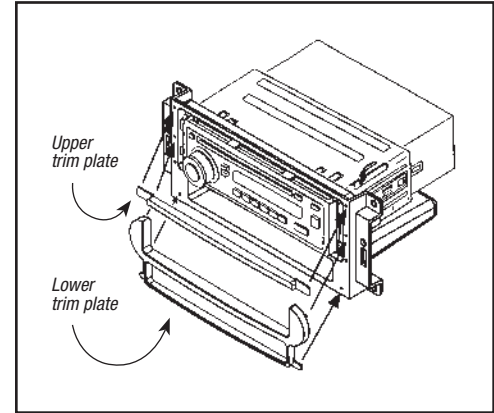

(Figure C)



Kit Assembly 99-6507

ISO radio provision with pocket

1. Mount the ISO Brackets to the radio using the screws supplied with the radio. (Figure A)
Note: You will need to remove the aftermarket radio's trim ring if equipped.
2. Slide the radio into the opening until it snaps into place. (Figure B)

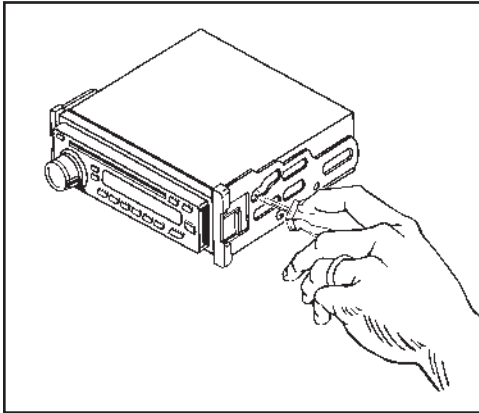

(Figure A)

3. Using the alignment pins on the trim plates & the corresponding holes in the housing, attach the upper trim plate and the lower trim plate supplied with the kit. (Figure B)
4. Locate the factory wiring harness in the dash. Metra recommends using the proper mating

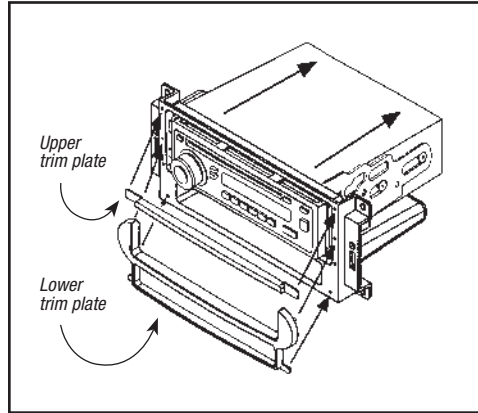

(Figure B)

adapter from Metra or AXCESS. Re-connect the negative battery terminal and test the unit for proper operation.

5. Reassemble dash in reverse order of disassembly.



INSTALLATION INSTRUCTIONS FOR PART 99-6507



REV. 9/18/2013 INST99-6507



KNOWLEDGE IS POWER

Enhance your installation and fabrication skills by enrolling in the most recognized and respected mobile electronics school in our industry. Log onto www.installerinstitute.com or call 800-354-6782 for more information and take steps toward a better tomorrow.

**Metra recommends MECP
certified technicians**

METRA. The World's best kits.™

1-800-221-0932

metraonline.com

© COPYRIGHT 2004-2011 METRA ELECTRONICS CORPORATION



INSTRUCCIONES DE INSTALACIÓN PARA LA PIEZA 99-6507

APLICACIONES

Lista de aplicaciones dentro

Dodge/Chrysler/Jeep/Mitsubishi multi-kit 2005 y mas 99-6507

CARACTERÍSTICAS DEL KIT

- Provisión de radio DIN con bolsillo
- Provisión de radio ISO DIN con bolsillo



COMPONENTES DEL KIT

- A) Carcasa del radio • B) Soportes ISO a presión • C) Placas de moldura (superior e inferior)

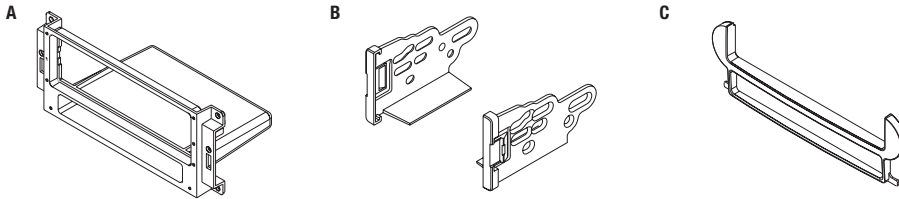

CABLEADO Y CONEXIONES DE ANTENA

Arnés de cableado: (se venden por separado)

- CHT0-01 - Arnés Chrysler con amplificador 2004 y mas
- XSVI-6502-NAV - Arnés R.A.P. Chrysler 2004 y mas

Adaptador de antena:

- 40-CR10 - Adaptador de antena Chrysler 2002 y mas

HERRAMIENTAS REQUERIDAS

- Herramienta de remoción de panel
- Destornillador Phillips • Llave de tubo
- Destornillador de hoja plana pequeño

PRECAUCIÓN: Metra recomienda desconectar el terminal negativo de la batería antes de comenzar cualquier instalación. Todos los accesorios, interruptores y, especialmente, las luces indicadoras de airbag deben estar enchufados antes de volver a conectar la batería a comenzar el ciclo de ignición.

NOTA: Remítase a las instrucciones incluidas con el radio de postventa.



99-6507

Aplicaciones

Chrysler

300.....	2005-2007
Aspen.....	2007
PT Cruiser.....	2006-2010

Dodge

Charger.....	2005-2007
Caliber.....	2007-2008
Dakota.....	2005-2007
Durango.....	2004-2007
Magnum.....	2005-2007
Ram 2006-2008 (<i>consola central completa</i>)	
2500/3500.....	2009
2500/3500 chassis cab.....	2010
Ram 2006-2008 (<i>consola central pequeña</i>)	
2500/3500.....	2009
2500/3500 chassis cab.....	2010

Dodge (*seguido*)

Ram 2006-2008 (<i>sin consola central</i>)	
2500/3500.....	2009
2500/3500 chassis cab.....	2010

Jeep

Commander.....	2006-2007
Compass.....	2007-2008
Grand Cherokee.....	2005-2007
Patriot.....	2007-2008

Mitsubishi

Raider.....	2006-2007
-------------	-----------

Índice

Desmontaje del tablero

- Chrysler 300 2005-2007	4
- Chrysler Aspen 2007	3
- Chrysler PT Cruiser 2006-2010	8
- Dodge Charger 2005-2007	3
- Dodge Caliber 2007-2008	7
- Dodge Dakota 2005-2007	3
- Dodge Durango 2004-2007	3
- Dodge Magnum 2005-2007	3
- Dodge Ram 2006-2008 (<i>consola central completa</i>), 2500/3500 2009, 2500/3500 chassis cab 2010	6
- Dodge Ram 2006-2008 (<i>consola central pequeña</i>), 2500/3500 2009, 2500/3500 chassis cab 2010	5
- Dodge Ram 2006-2008 (<i>sin consola central</i>), 2500/3500 2009, 2500/3500 chassis cab 2010	4
- Jeep Commander 2006-2007	8
- Jeep Compass 2007-2008	7
- Jeep Grand Cherokee 2005-2007	7
- Jeep Patriot 2007-2008.....	7
- Mitsubishi Raider 2006-2007	9

Ensamble del kit

- Provisión de radio DIN con bolsillo	10
- Provisión de radio ISO con bolsillo	11



Desmontaje del tablero 99-6507

Chrysler Aspen 2007, Dodge Dakota 2005-2007/Durango 2004-2007

1. Retire los (2) tornillos de 7 mm de la parte interior del bolsillo hacia arriba. (Figura A)
2. Suelte y retire todo el panel de la moldura que rodea el radio y los controles de clima. (Figura B)
3. Retire los (4) tornillos de 7 mm que sostienen el radio. Desconecte y retire el radio. (Figura C)

Continuará al ensamble del kit

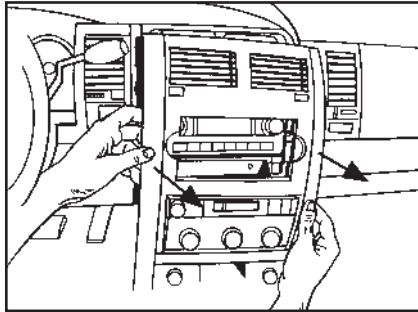

(Figura B)

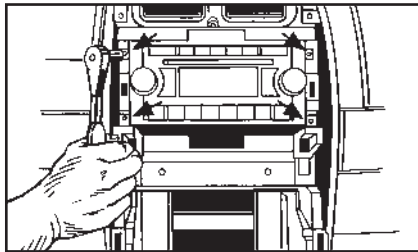

(Figura C)

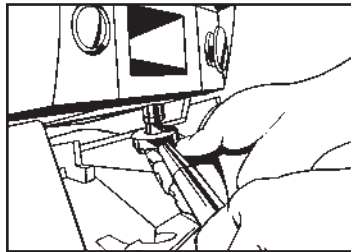

(Figura A)

Dodge Charger/Magnum 2005-2007

1. Suelte y retire todo el panel que rodea el radio y los controles del clima, incluyendo las rejillas del aire acondicionado. (Figura A)
2. Retire los (4) tornillos de 7 mm que sostienen el radio. Desconecte y retire el radio. (Figura B)

Continuará al ensamble del kit

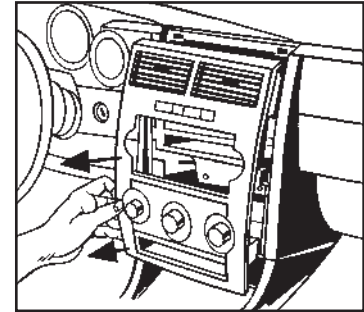

(Figura A)

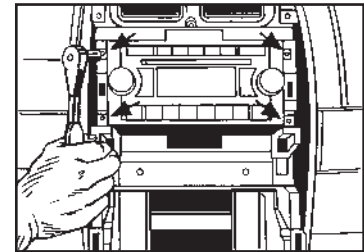

(Figura B)

Chrysler 300 2005-2007

1. Suelte y retire todo el panel que rodea el radio y los controles del clima, incluyendo las rejillas del aire acondicionado y el reloj. (Figura A)
2. Retire los (4) tornillos de 7 mm que sostienen el radio. Desconecte y retire el radio. (Figura B)

Continuará al ensamble del kit

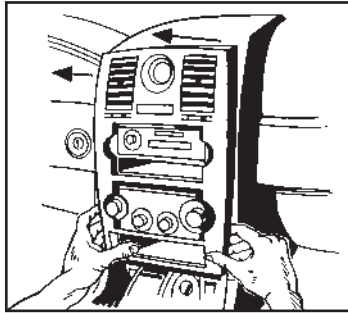

(Figura A)

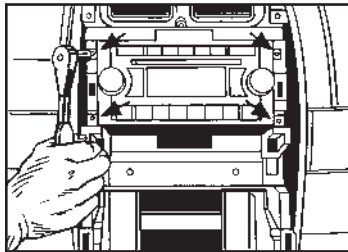

(Figura B)

Dodge Ram 2006-2008, 2500/3500 2009, 2500/2300 chasis cab 2010

(sin consola central)

1. Abra el portavasos y retire los (2) tornillos Phillips que están hacia arriba en el borde frontal del panel del radio/control de clima. (Figura A)
2. Suelte y retire todo el panel que rodea el radio y los controles del clima, incluyendo las rejillas del aire acondicionado. (Figura B)
3. Retire los (4) tornillos de 7 mm que sostienen el radio. Desconecte y retire el radio.

Continuará al ensamble del kit

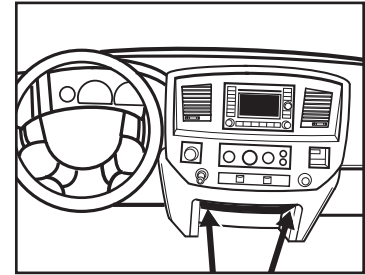

(Figura A)

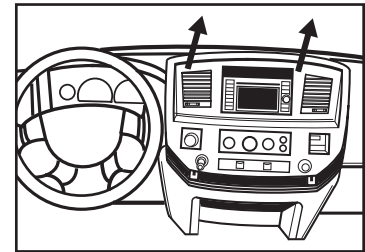

(Figura B)



Desmontaje del tablero 99-6507

Dodge Ram 2006-2008, 2500/3500 2009, 2500/2300 chasis cab 2010 (consola central *pequeña*)

1. Si el vehículo tiene palanca de velocidades al piso, quite la perilla de la palanca. Retire los insertos de la consola central, si los hay. (Figura A)
2. Retire los tornillos que sujetan la consola central trasera al panel del piso. Levante la consola central trasera para despejar el área de la palanca de velocidades, si la hay. (Figura B)
3. Retire los tornillos que sujetan la consola central delantera al panel del piso. Suelte y retire la consola central delantera. (Figura C)
4. Retire los (2) tornillos de cabeza Phillips de la parte inferior del tablero. Suelte y retire el panel inferior.
5. Retire los (2) tornillos Phillips que están hacia arriba en el borde frontal

del panel del radio/control de clima. (Figura D)

6. Suelte y retire todo el panel que rodea el radio y los controles del clima, incluyendo las rejillas del aire acondicionado. (Figura E)
7. Retire los (4) tornillos de 7 mm que sujetan el radio al tablero y retire el radio.

Continuará al ensamble del kit

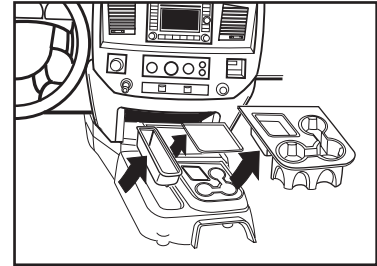

(Figura A)

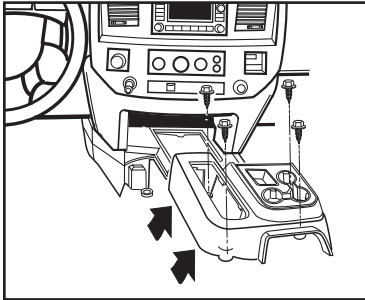

(Figura B)

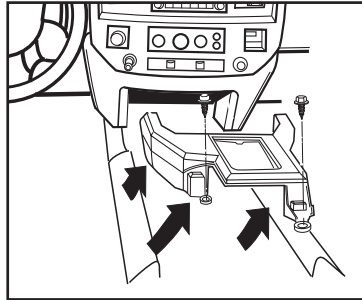

(Figura C)

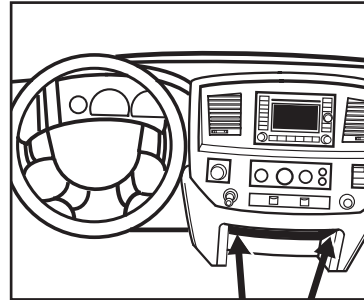

(Figura D)

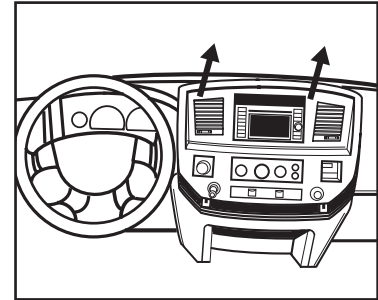

(Figura E)



Desmontaje del tablero 99-6507

Dodge Ram 2006-2008, 2500/3500 2009, 2500/2300 chasis cab 2010 (consola central completa)

1. Si el vehículo tiene palanca de velocidades al piso, quite la perilla de la palanca.
2. Suelte y retire la cubierta superior del frente de la consola (más cercana al tablero). (Figura A)
3. Retire los (2) tornillos de 8 mm de debajo de la cubierta de la consola (anteriormente retirada).
4. Afloje los (2) tornillos de 8 mm de la parte inferior del tablero. Suelte el panel inferior.
5. Retire los (2) tornillos Phillips que están hacia arriba en el borde frontal del panel del radio/control de clima. (Figura C)
6. Suelte y retire todo el panel que rodea el radio y los controles del clima, incluyendo las rejillas del aire acondicionado. (Figura D)
7. Retire los (4) tornillos de 7 mm que sujetan el radio al tablero y retire el radio.

Continuará al ensamble del kit

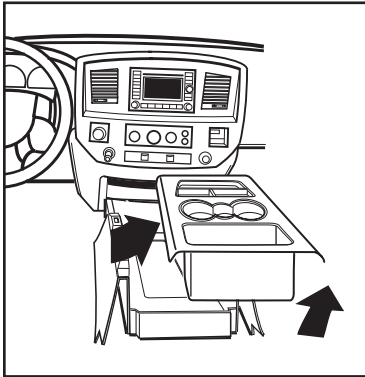

(Figura A)

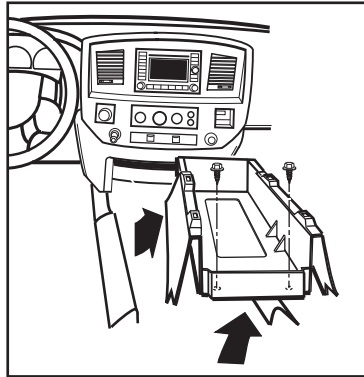

(Figura B)

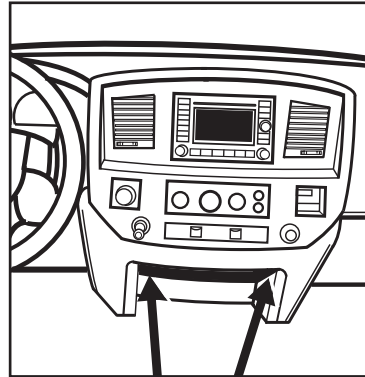

(Figura C)

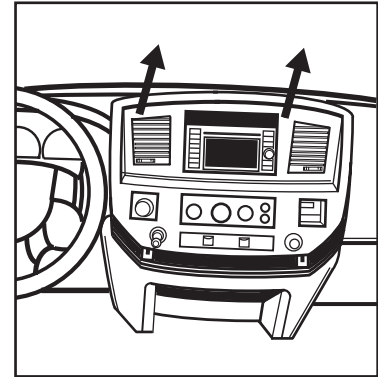

(Figura D)



Desmontaje del tablero 99-6507

Dodge Caliber 2007-2008, Jeep Compass/Patriot 2007-2008

1. Suelte y mueva la moldura de la palanca de velocidades a un lado. (Figura A)
2. Suelte y retire el panel superior del tablero central sobre las rejillas del aire acondicionado (solo Compass y Patriot).
3. Suelte el panel de la moldura del tablero central (no lo retire hasta que se hayan retirado los controles de clima). (Figura A)
4. Retire los (4) tornillos Phillips que sostienen el panel de control de clima a la parte posterior del panel del tablero central.
5. Retire los (4) tornillos de 7 mm que sostienen el radio. Desconecte y retire el radio.

Continuará al ensamble del kit

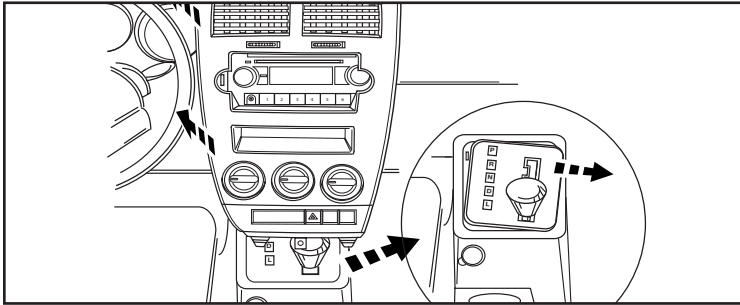

(Figura A)

Jeep Grand Cherokee 2005-2007

1. Suelte y retire el panel de alrededor del radio, incluyendo la rejilla a cada lado. (Figura A)
2. Retire los (4) tornillos de 7 mm que sostienen el radio. Desconecte y retire el radio. (Figura B)

Continuará al ensamble del kit

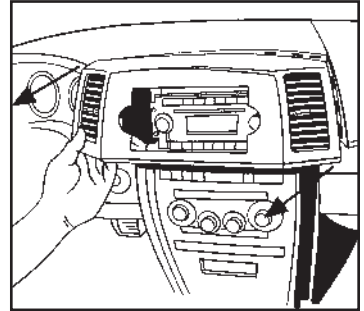

(Figura A)

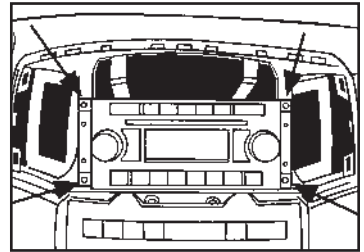

(Figura B)

Desmontaje del tablero 99-6507

Jeep Commander 2006-2007

1. Retire los (16) tornillos que aseguran el panel de la moldura del radio. (Figura A)
2. Suelte y retire todo el panel de la moldura del radio. (Figura B)
3. Retire los (4) tornillos de 7 mm que sostienen el radio. Desconecte y retire el radio.

Continuará al ensamble del kit

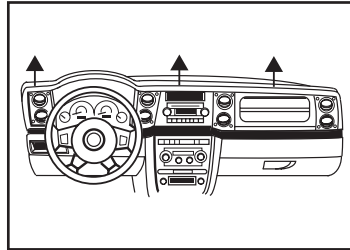

(Figura B)

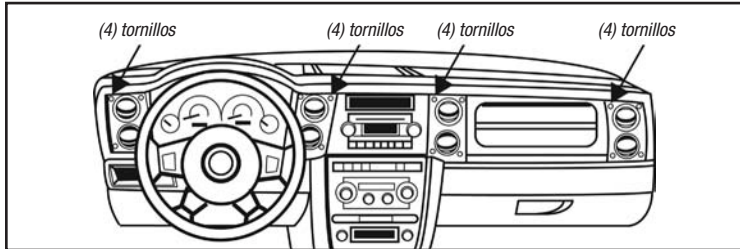

(Figura A)

Chrysler PT Cruiser 2006-2010

1. Retire los (2) tornillos de las rejillas interiores en el panel del tablero central. (Figura A)
2. Suelte el panel del tablero central (no lo retire hasta que se hayan retirado los controles de clima). (Figura A)
3. Retire los (4) tornillos Phillips que sostienen el panel de control de clima a la parte posterior del panel del tablero central.
4. Retire los (4) tornillos de 7 mm que sostienen el radio. Desconecte y retire el radio.

Continuará al ensamble del kit

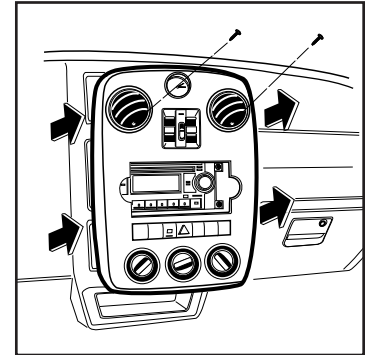

(Figura A)

**Mitsubishi Raider
2006-2007**

Notas

1. Suelte y retire el panel del tablero central. (Figura A)
2. Retire los (4) tornillos de 7 mm que sostienen el radio. Desconecte y retire el radio.

Continuará al ensamble del kit

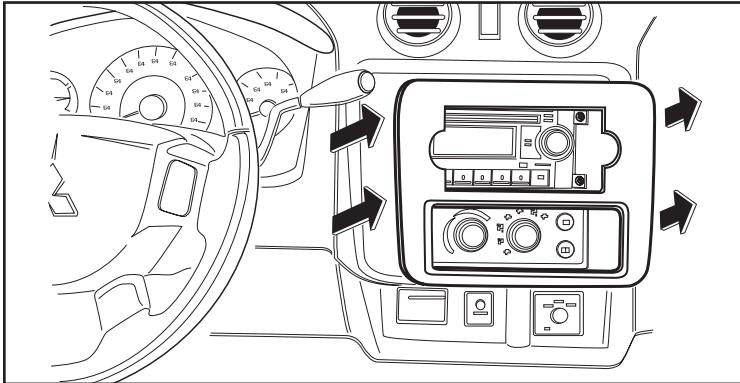

(Figura A)



Ensamble del kit 99-6507

Provisión de radio DIN con bolsillo

1. Deslice la reja DIN en la carcasa del radio y sujétela doblando hacia abajo las pestañas de metal. (Figura A)

Nota: Deberá retirar el aro de moldura del radio de mercado secundario si es parte del equipamiento.

2. Deslice la unidad central de mercado secundario en la reja y sujétela. (Figura B)

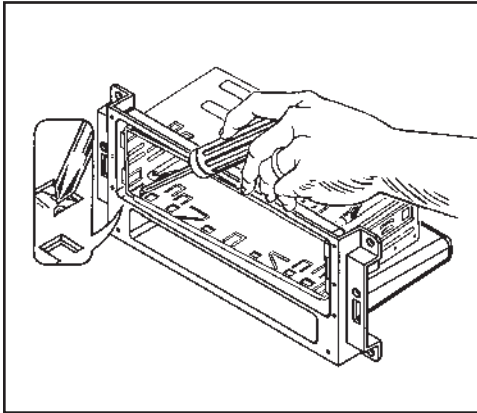

(Figura A)

3. Usando las espigas de alineación de las placas de la moldura y los orificios correspondientes de la carcasa, una las placas de moldura superior e inferior suministradas con el kit. (Figura B)
4. Ubique el arnés del cableado de fábrica en el tablero. Metra recomienda usar el adaptador de acoplamiento adecuado de Metra o AXXESS.

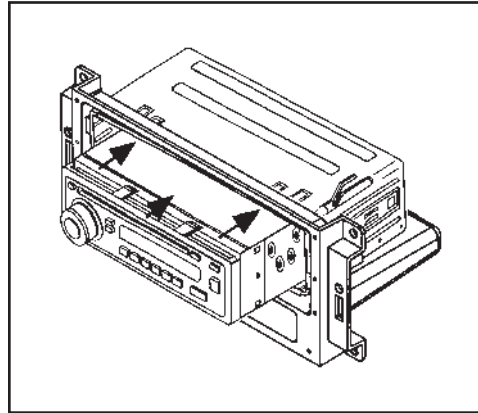

(Figura B)

Vuelva a conectar el terminal negativo de la batería y pruebe la unidad para verificar que funcione correctamente.

5. Vuelva a montar el tablero en forma inversa al desmontaje.

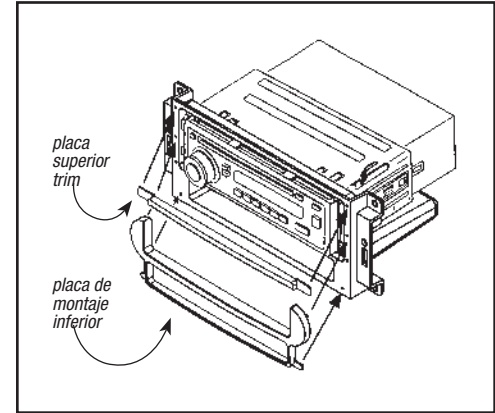

(Figura C)



Ensamble del kit 99-6507

Provisión de radio ISO con bolsillo

1. Monte los soportes ISO en el radio con los tornillos incluidos con el radio. (Figura A)

Nota: Deberá retirar el aro de moldura del radio de mercado secundario si es parte del equipamiento.

2. Deslice el radio en la apertura hasta que entre a presión. (Figura B)

3. Usando las espigas de alineación de las placas de la moldura y los orificios correspondientes de la carcasa, una las placas de moldura superior e inferior suministradas con el kit. (Figura B)
4. Ubique el arnés del cableado de fábrica en el tablero. Metra recomienda usar el adaptador

de acoplamiento adecuado de Metra o AXCESS. Vuelva a conectar el terminal negativo de la batería y pruebe la unidad para verificar que funcione correctamente.

5. Vuelva a montar el tablero en forma inversa al desmontaje.

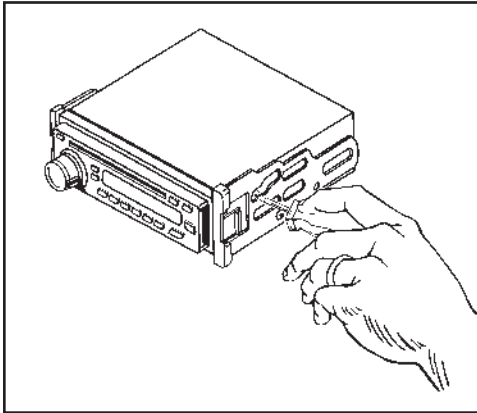

(Figura A)

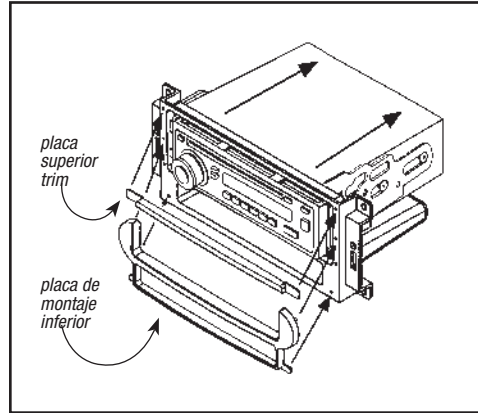

(Figura B)



INSTRUCCIONES DE INSTALACIÓN PARA LA PIEZA 99-6507



REV.9/18/2013 INST99-6507



EL CONOCIMIENTO ES PODER

Mejore sus habilidades de instalación y fabricación inscribiéndose en la escuela de dispositivos electrónicos móviles más reconocida y respetada de nuestra industria. Regístrese en www.installerinstitute.com o llame al 800-354-6782 para obtener más información y avance hacia un futuro mejor.



Metra recomienda técnicos con certificación del Programa de Certificación en Electrónica Móvil (Mobile Electronics Certification Program, MECP).